

Camera Moving Model Scanner

FREEDOM X5

USER MANUAL

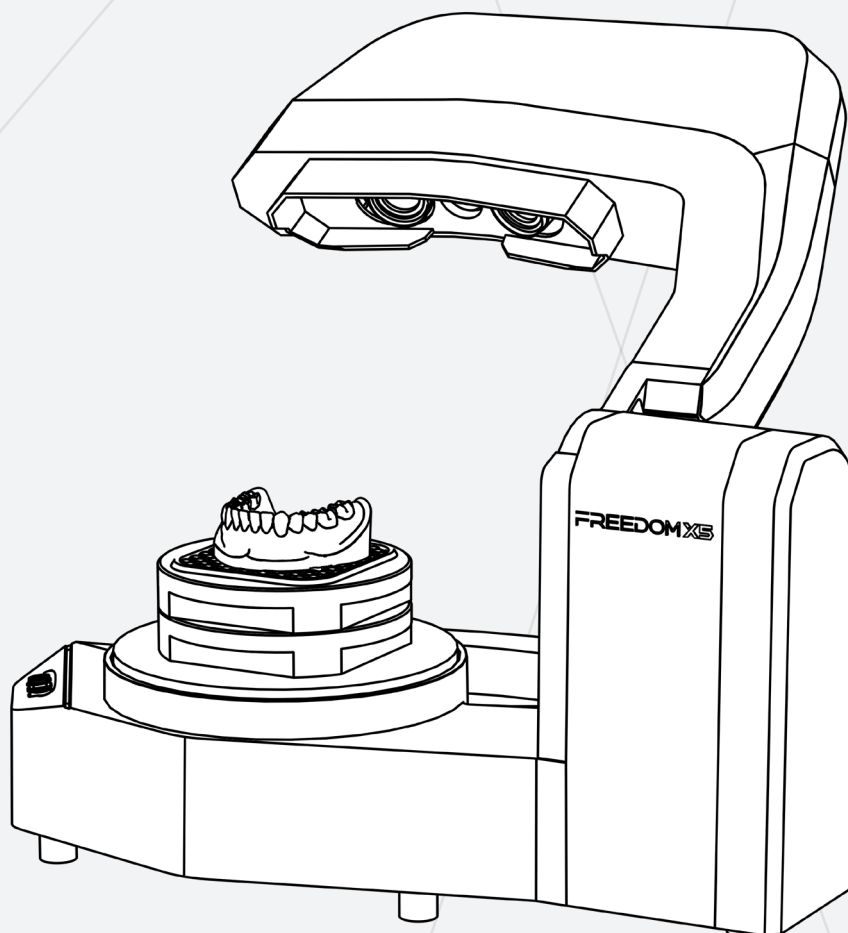

CONTENTS

Precautions	3
Components	4
Product Details	5
Plate	7
Scanner Installation	9
PC Requirements	9
Software Installation	10
ScanApp	11 - 13
Language Settings	14
Calibration	16
Mouse Instructions	18
Description of Icons	19 - 23
Scanning Instructions	24 - 37
Worldwide Official Network	38

■ Installation Precautions

- When installing the product, avoid direct sunlight.
if the projector is exposed to direct sunlight, it will degrade the quality of scanned data.
- After powering the scanner, it needs to warm up for about 10 seconds before you can start using the Scan Program.
- To obtain the best scan data, avoid using the scanner and wireless USB devices together. If you use the scanner with a wireless USB device such as a USB wireless LAN card, scanning might fail.
- We recommend that you perform calibration once a month.
Additionally, you must perform calibration when physically relocating the scanner to another place.

■ Safety Precautions

- Do not look directly into the projector light during scanning operations.
The light emitted from the projector may be harmful to your eyes.

COMPONENTS

	<p>FREEDOM X Scanner</p>
	<p>Basic Accessories Plates Base plate (2ea), Calibration Plate (1ea), Multi-die plate (1ea)</p>
	<p>Power Unit AC Adapter (1ea)</p>
	<p>Accessories Blu Tack (1ea), Anti-slip Mesh Mat (2ea), Scan Target (5ea)</p>

PRODUCT DETAILS

■ Front Side

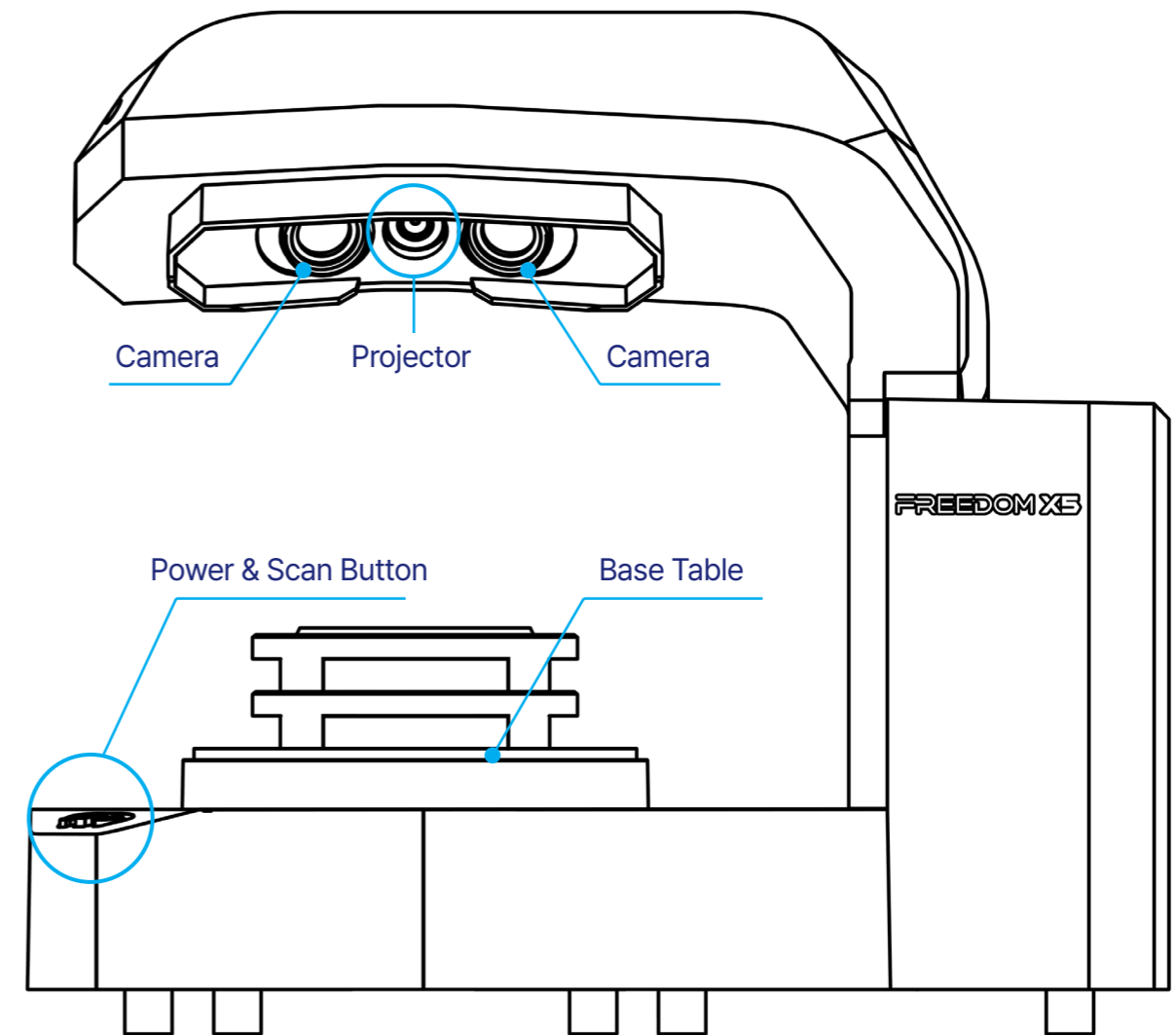

PRODUCT DETAILS

Back Side

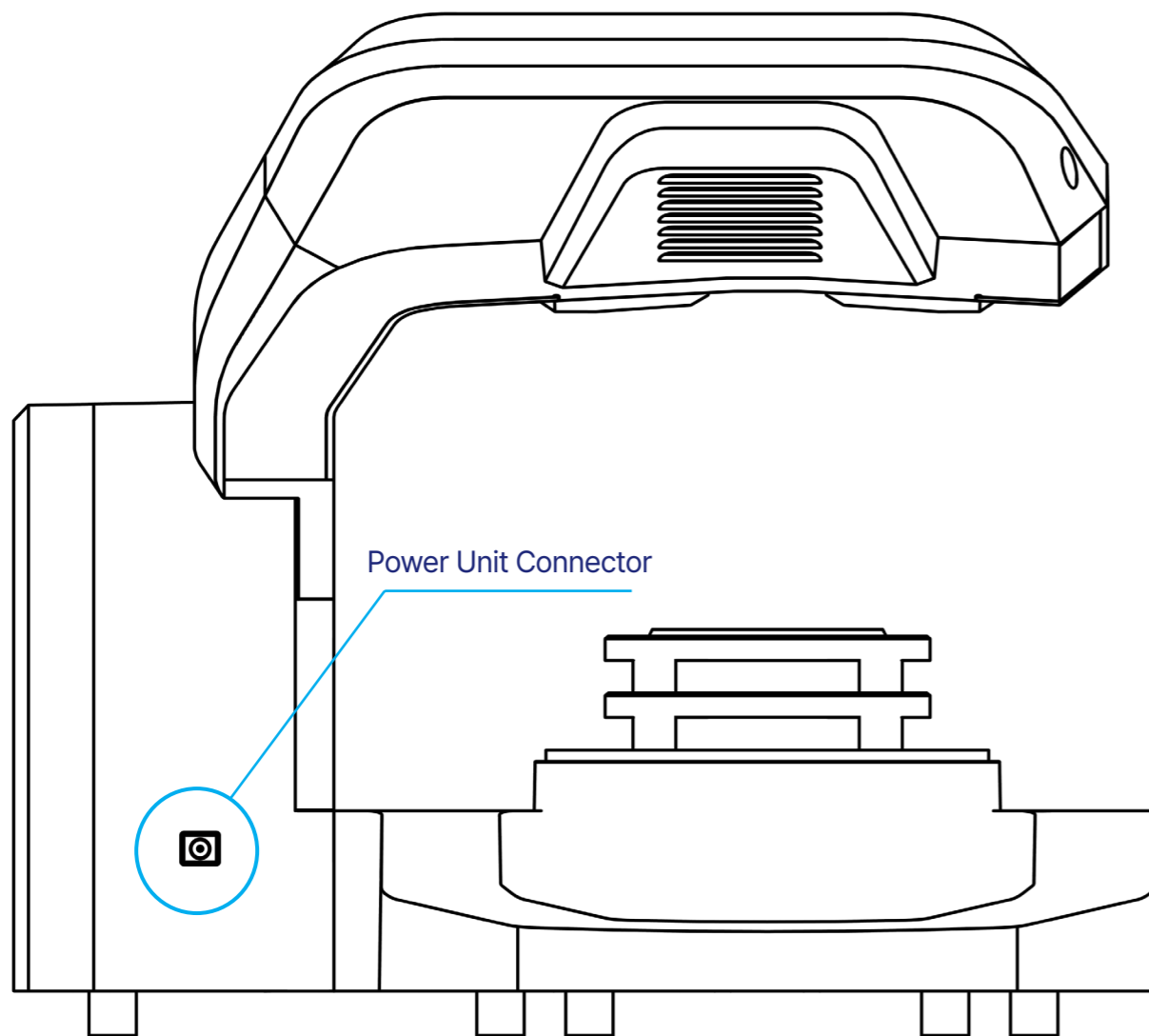

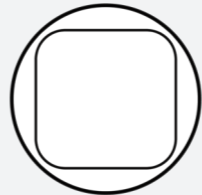
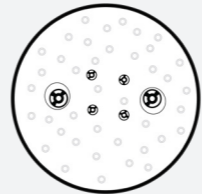
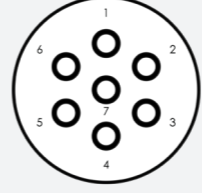

PLATE

Basic Plate Accessories

	<p>Base Plate Height Adjustment</p>
	<p>Calibration Plate Scanner Calibration</p>
	<p>Multi-die Plate 7 Unit Prep-die Scan</p>

■ **Optional Purchase Plates**

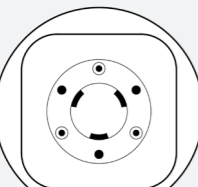
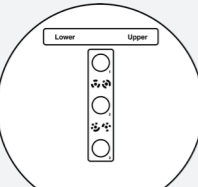
	<p>Transfer Plate A Artex Articulator</p>
	<p>Transfer Plate S KAVO, SAM Articulator</p>
	<p>Transfer Plate B Bio-Art Articulator</p>
	<p>Transfer Plate D Denar Articulator</p>
	<p>All-in-One Plate Upper, Lower, Die Scan at Once</p>

SCANNER INSTALLATION

- 1 Connect the power cable without switching on the scanner.
 - 2 Connect the scanner's USB cable to the 3.0 USB PORT on the back of the PC.
- ⚠ Do not use a USB wireless LAN card.

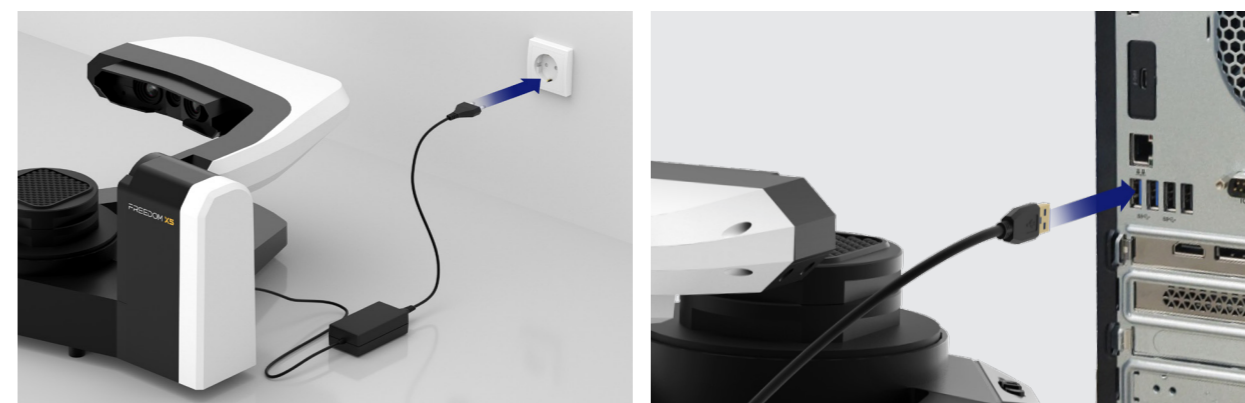

PC REQUIREMENTS

• O/S	Windows 10, 11 (64-Bit)
• RAM	32GB Above
• VGA	8GB Above (NVIDIA GeForce RTX3070 Above)
• HDD / SSD	500GB or above / 128GB or above
• CPU	i9-11900 (above Intel 11th Gen) ⚠ AMD CPU NOT COMPATIBLE
• USB Port	USB 3.0

* Compatibility issues may arise for assembled PCs and DOF is not responsible for any problems resulting from this. We recommend using an HP PC provided by DOF headquarters.

SOFTWARE

Software Installation

1 Install ScanApp that is included in the DOF USB.

(You can also download it from the DOF website.

Support > Software > ScanApp 3.0 for FREEDOM X5)

If help support arise, please contact the local supplier you made purchase with this product.

2 Proceed with installation by referring to the installation wizard.

⚠ Recommended to restart the PC after installation.

⚠ Before installing the scan program, it is recommended to update the operating system.

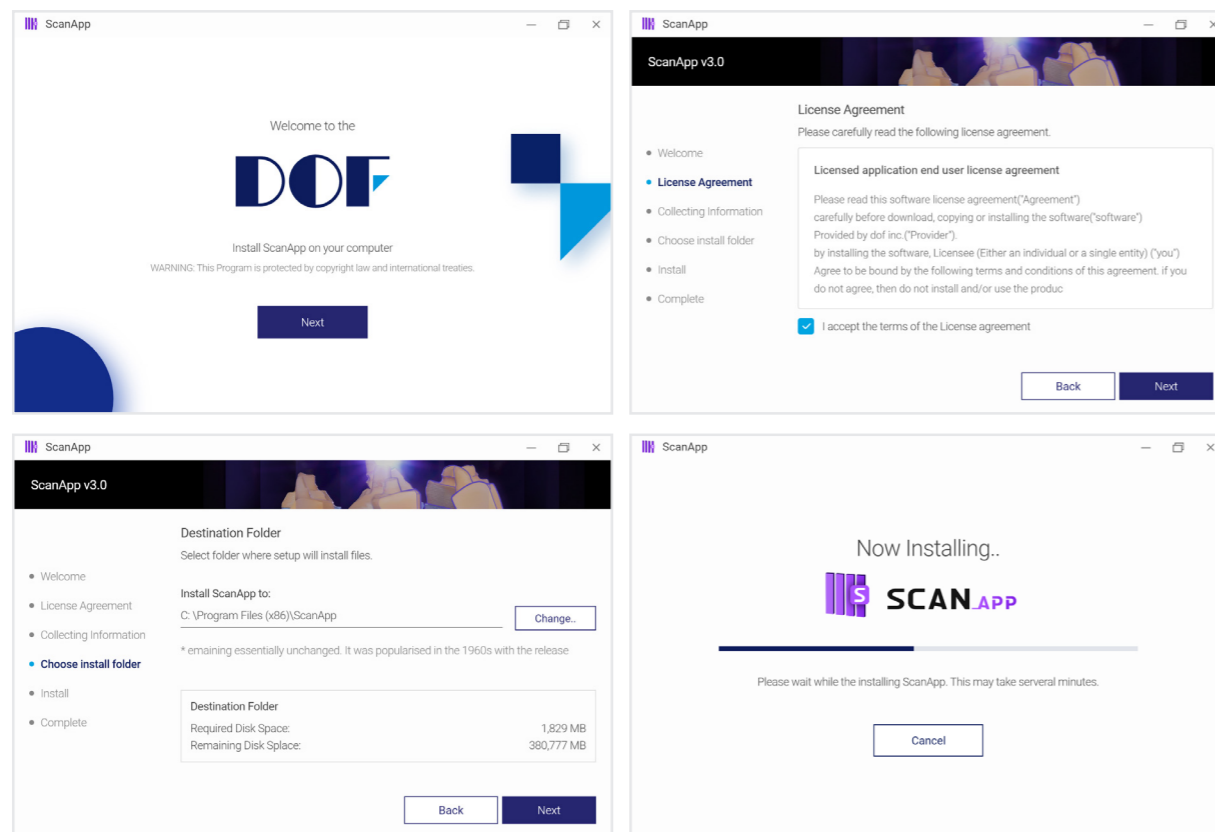

Start ScanApp

After installing ScanApp scanning software, integrate with DOF SYNC.

1 Check that the two softwares have been installed.

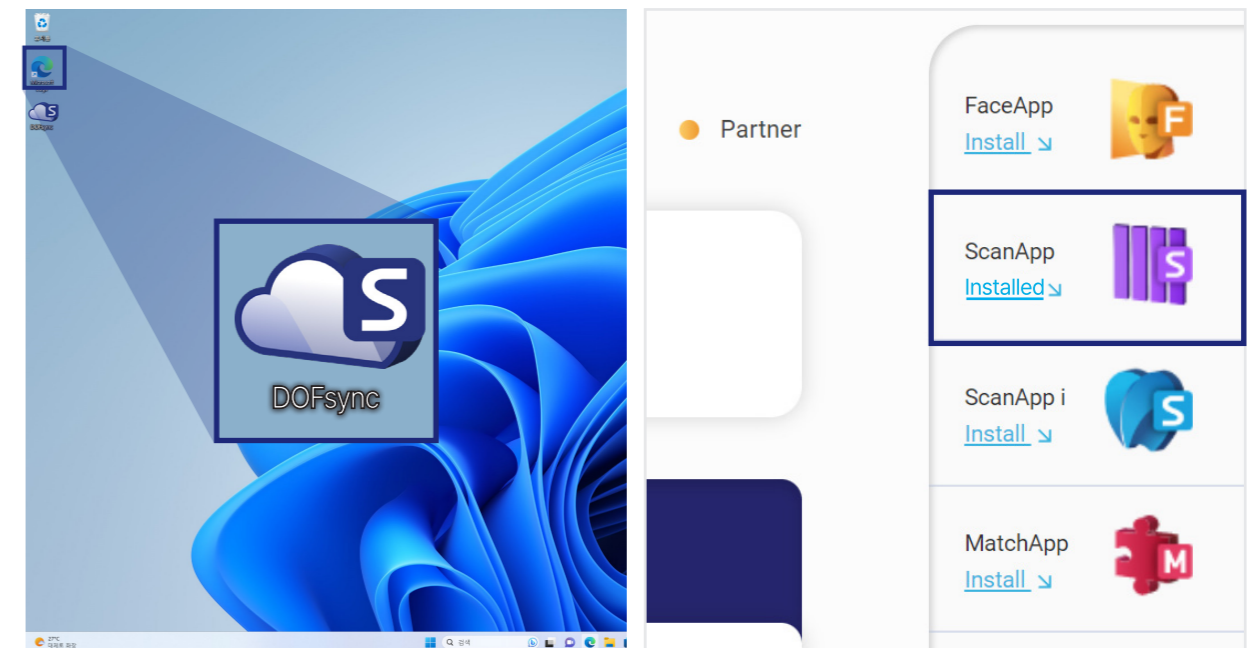

2 Run DOF SYNC first.

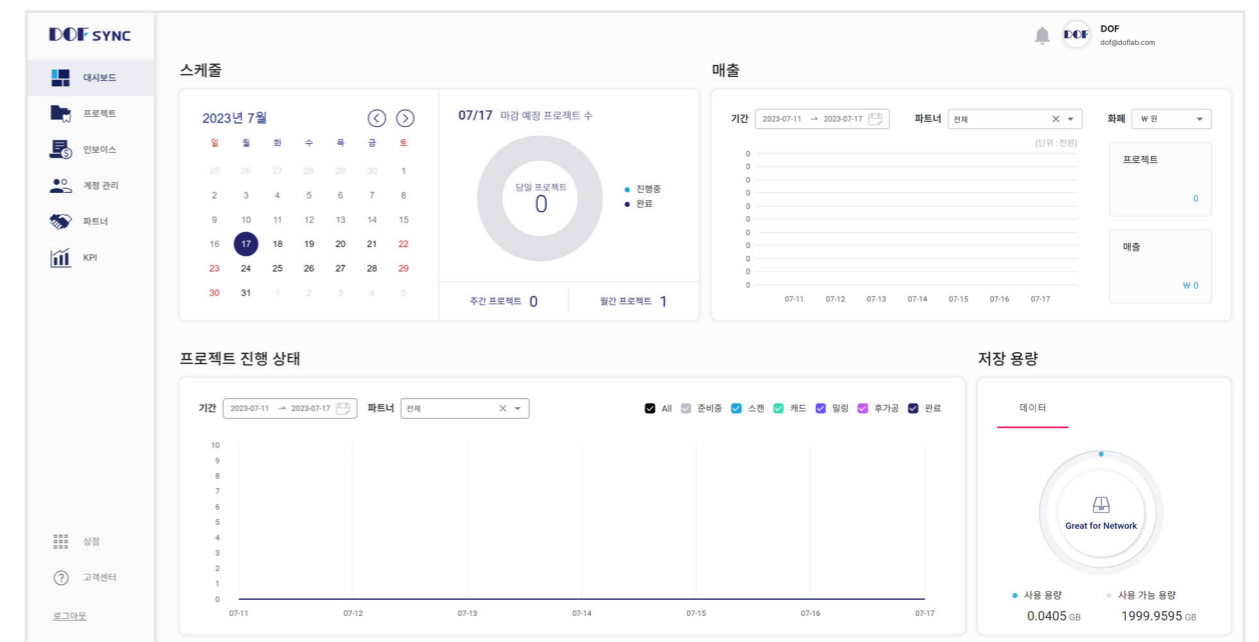

3 Click on the profile icon.

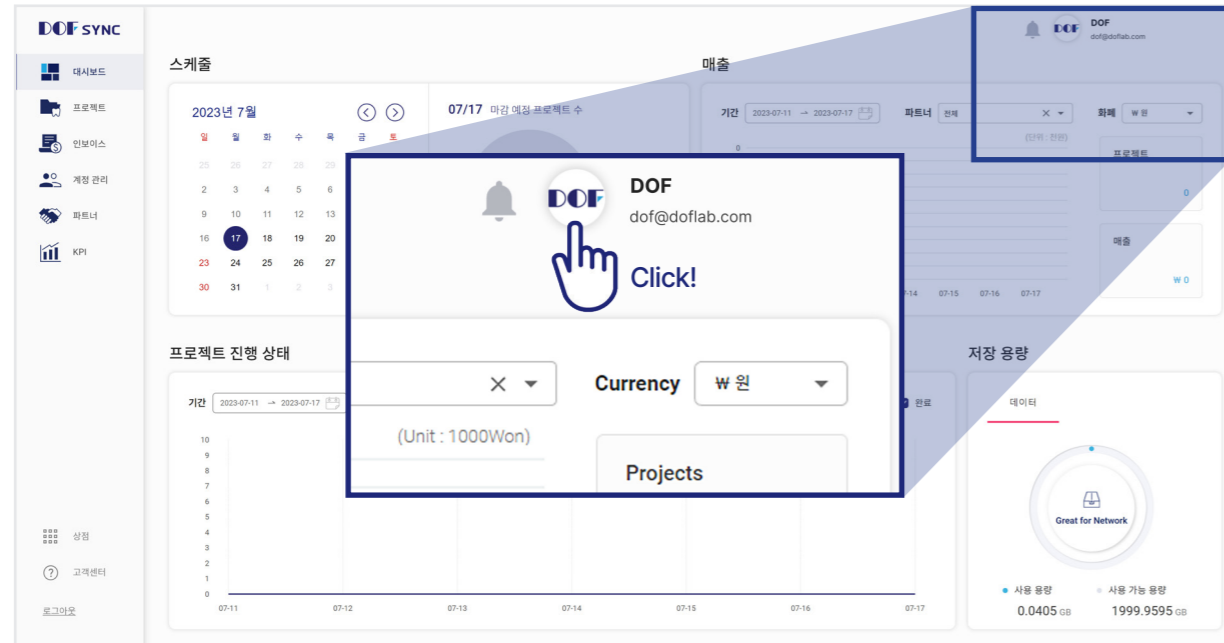

5 When the Software Settings window pops up, select ScanApp.

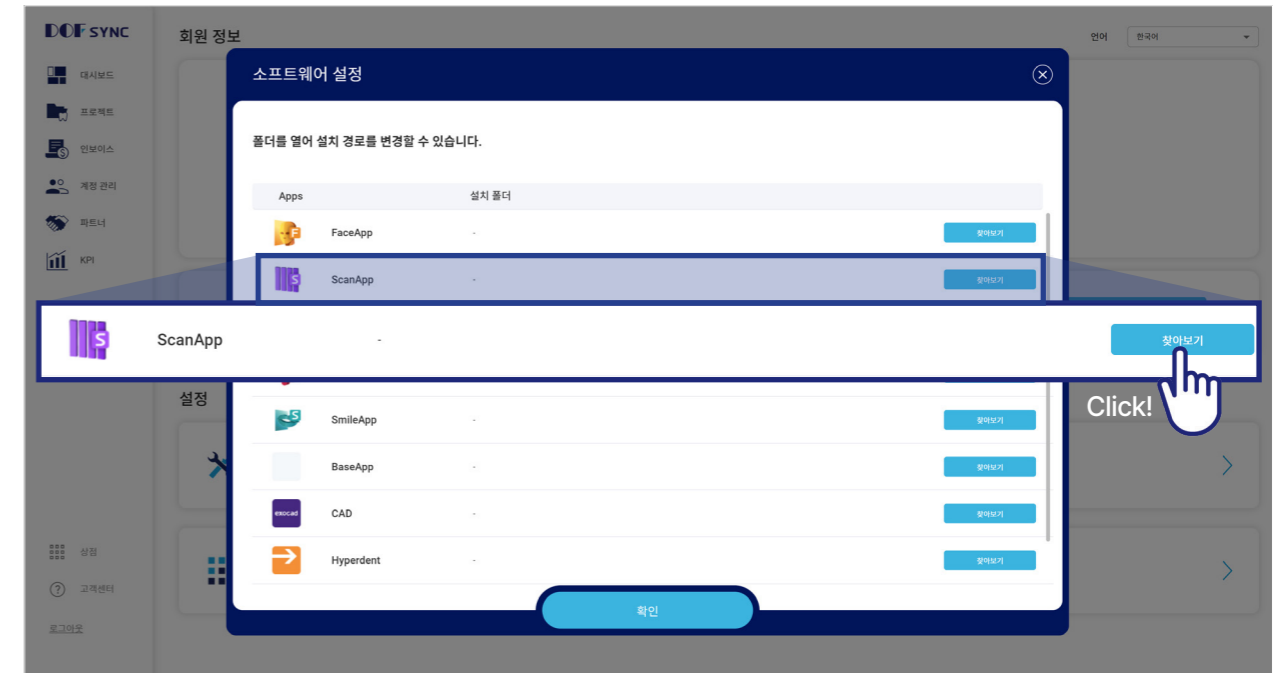

4 Scroll down to the Settings Tab and select Software button.

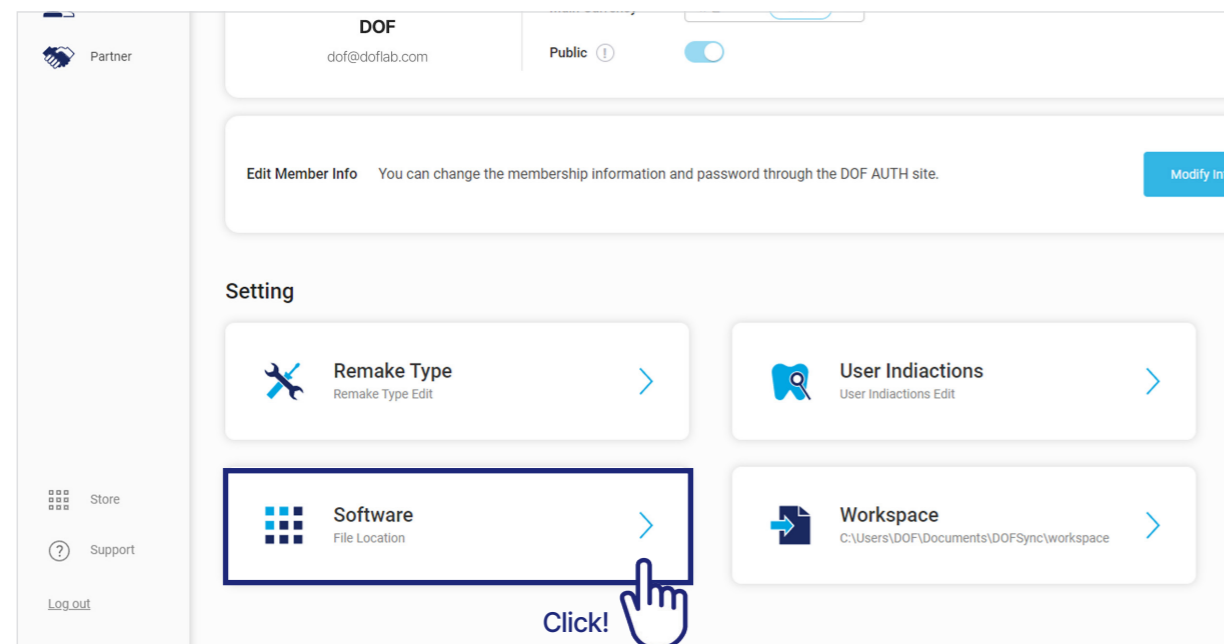

6 Find and select ScanApp.exe.

(ScanApp.exe can be found in C:\Program Files\DOFLab\ScanApp.)

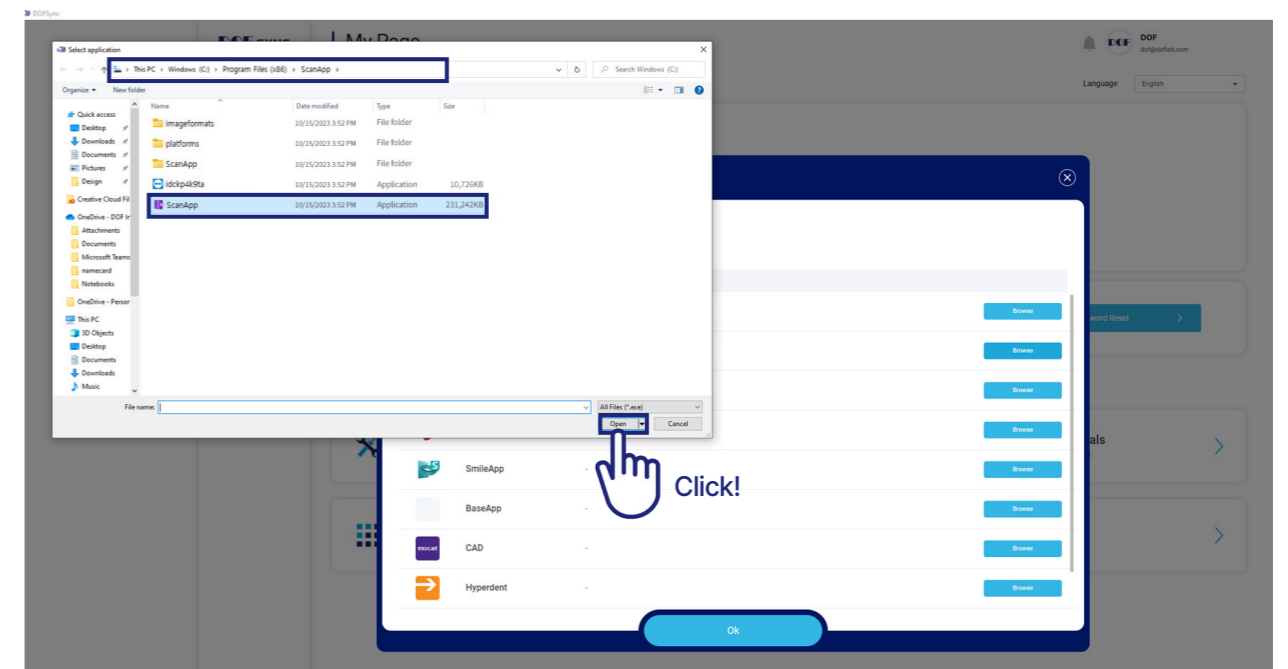

LANGUAGE SETTINGS

1 Run ScanApp.

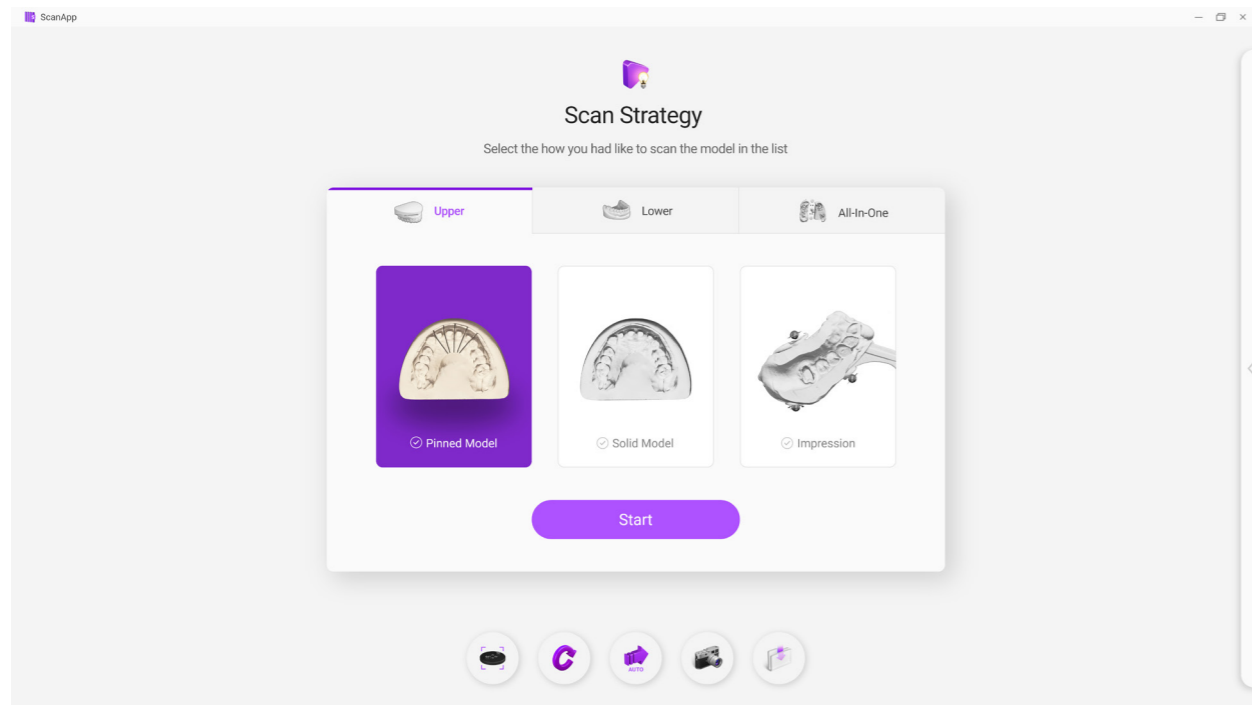

2 Select the arrow tab on the right side to open the options.

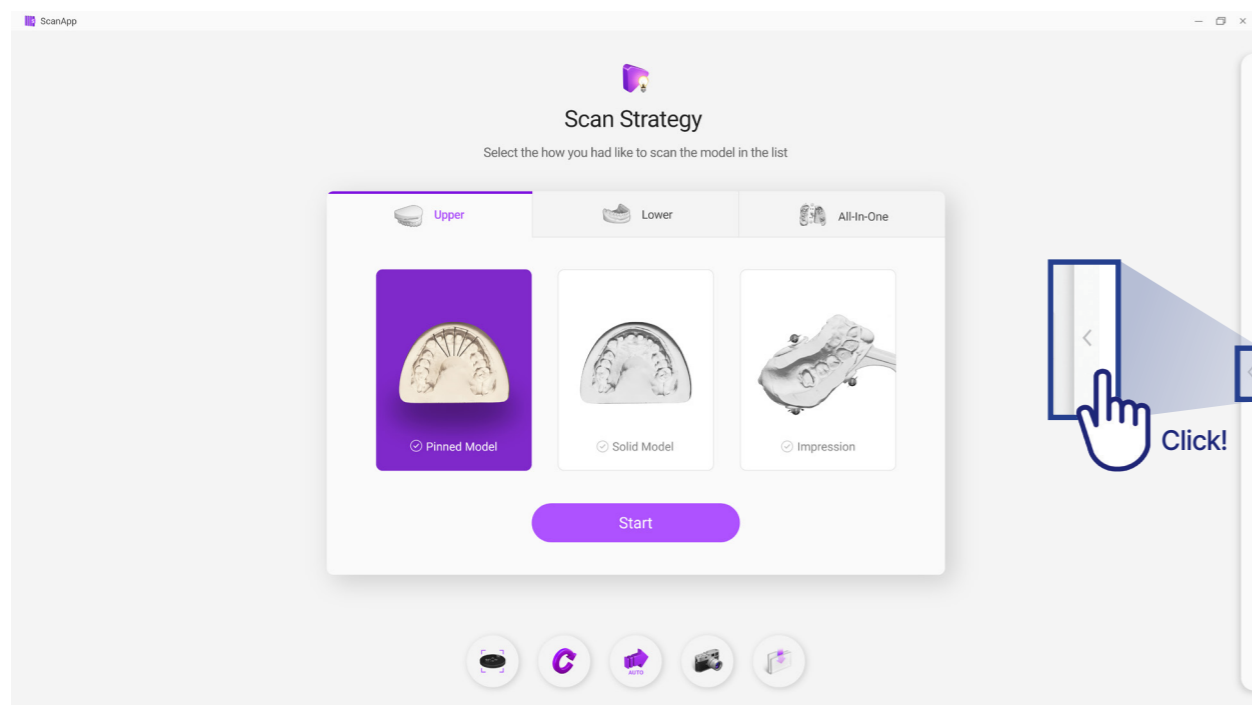

3 Select the desired language from the Language Settings.

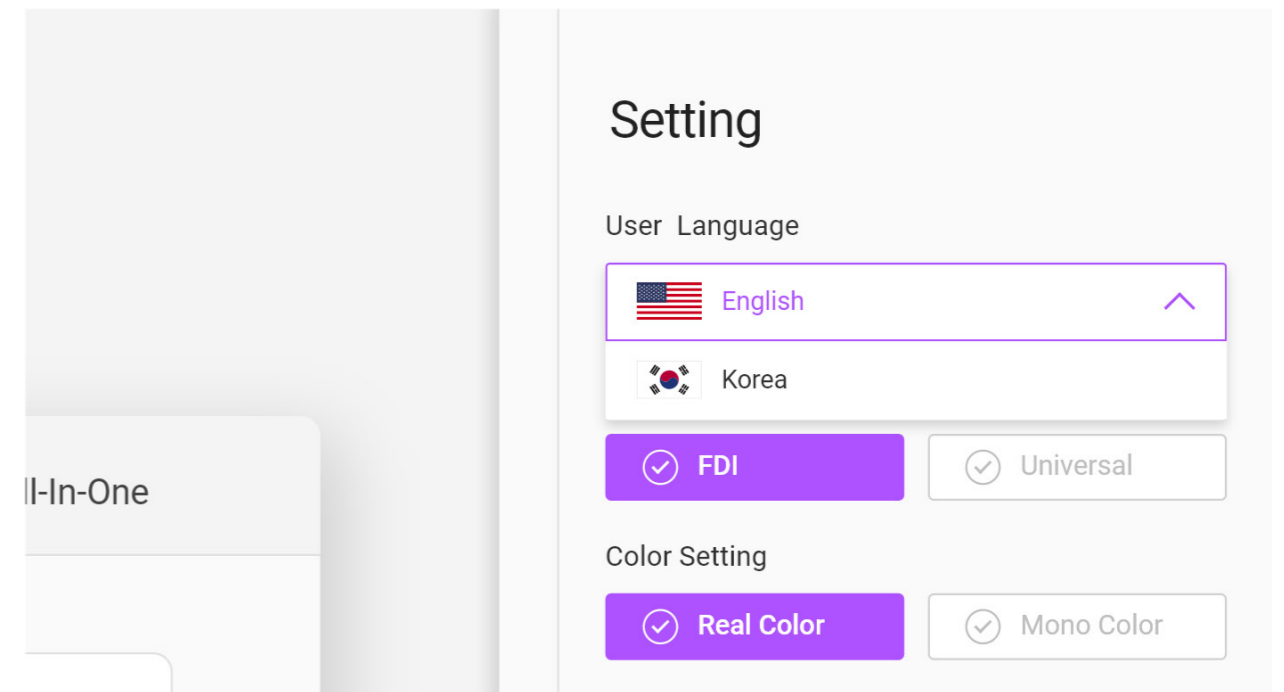

4 Close and Relaunch ScanApp for the new language to takes effect.

CALIBRATION

1 Press On to start the scanner.

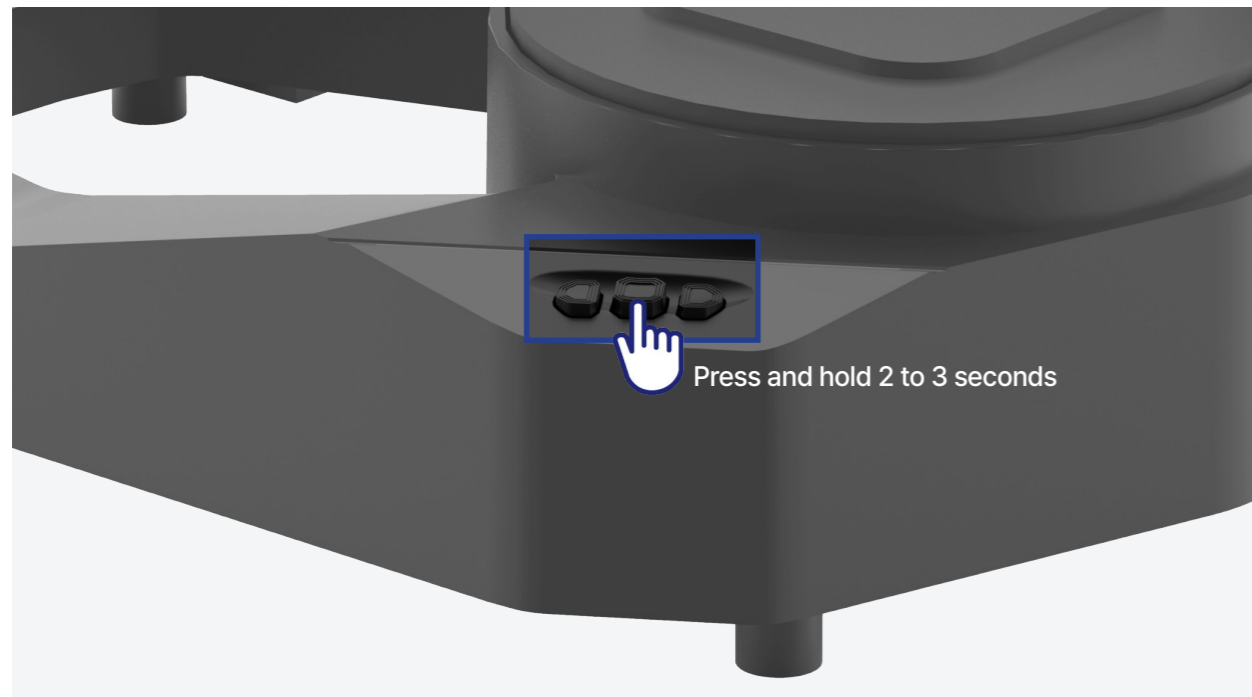

2 After launching ScanApp, please select the Calibration icon.

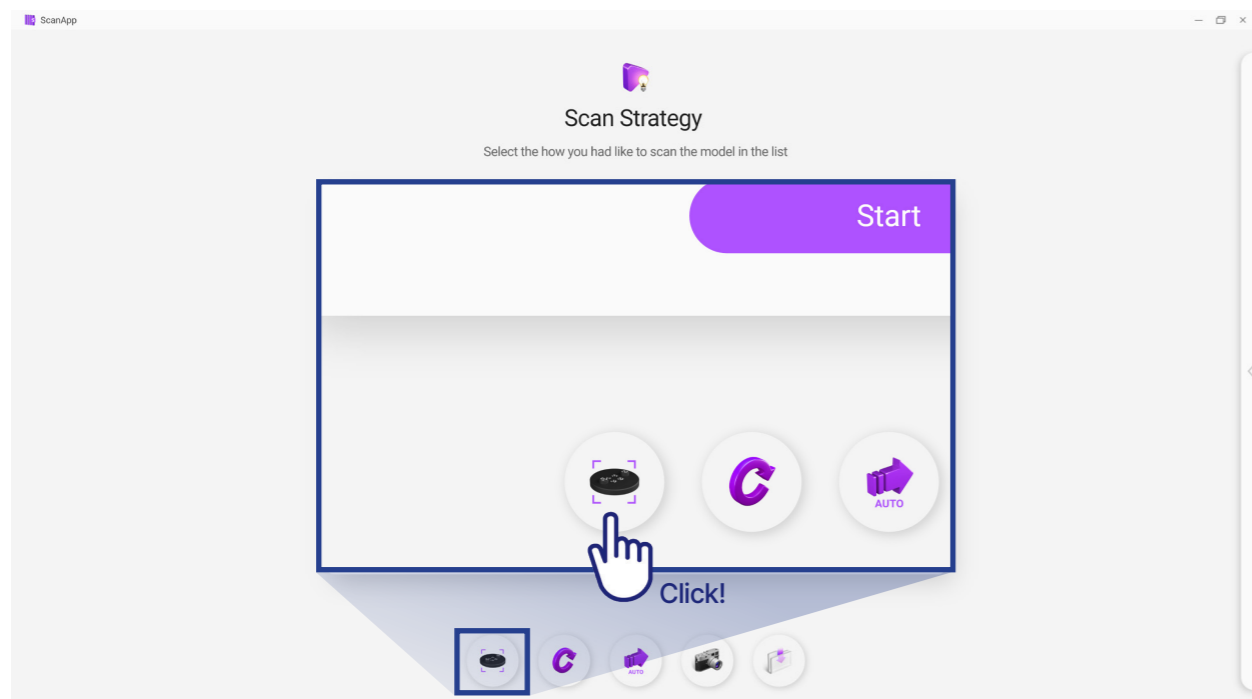

3 Please stack the two base plates on the scanner, and stack calibration plate on top of them.



4 Press the Calibration button to start calibration.

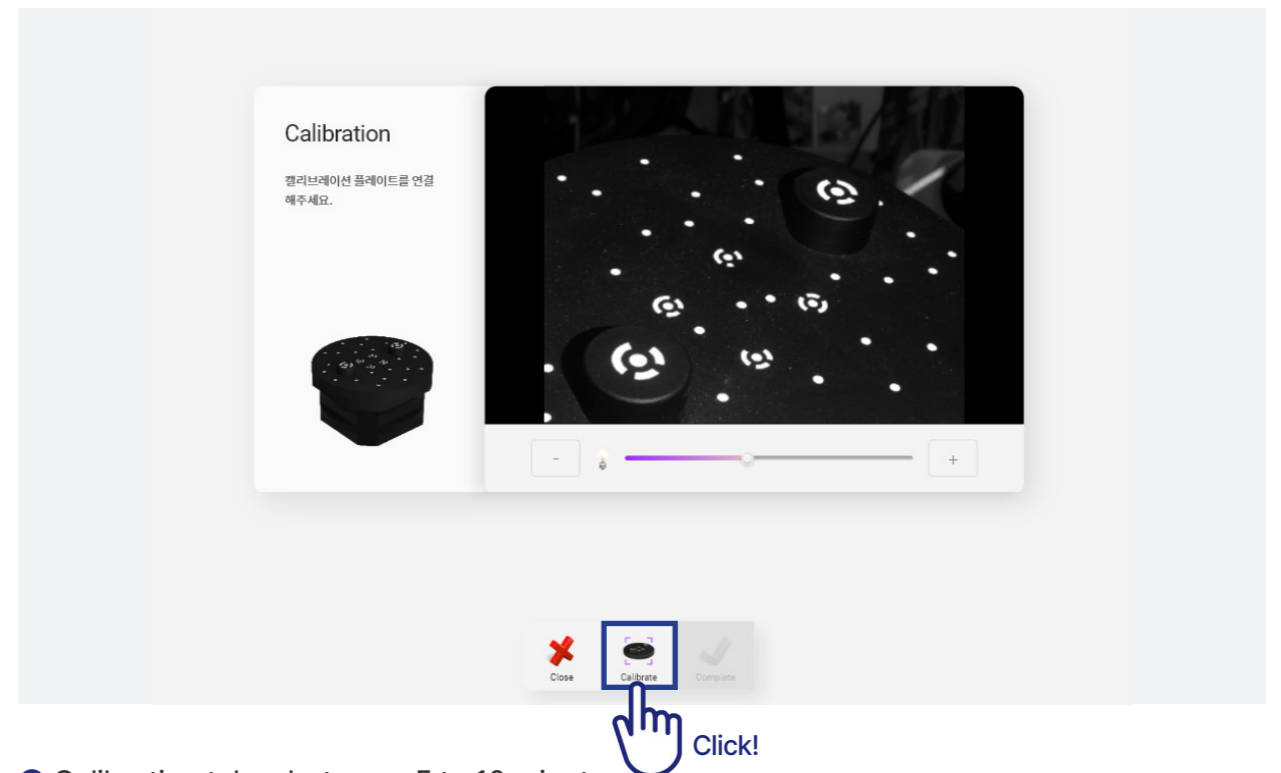





5 Calibration takes between 5 to 10 minutes.

⚠ It is recommended to calibrate the scanner once per month.

⚠ Calibration is recommended for scanner if physically moved to another location.

MOUSE SETTINGS

Mouse Button	Action	Explanation
 Left	Click	Select
	Hold & Drag	Rescan current data
 Right	Hold & Drag	View Rotation
 Both	Hold & Drag	View Movement
 Wheel	Scroll Up	Maximize
	Scroll Down	Minimize
	Hold & Drag	View Movement

DESCRIPTION OF ICONS

Main Tool



- 1 Calibration Scanner Calibration
- 2 Reload When order form needs to be changed, modify the project in SYNC, Pressing the Reload button will add or delete the required scanning processes.
- 3 Auto mode The scanning steps are moved automatically.
- 4 Camera You can turn the live view screen off or on.
- 5 Save Saving all the raw scan data as back up project, all the work done before clicking the Save button will be saved.



- 1 Close Cancel the scanning step and return to previous task.
- 2 STL Import If you already have a scanned file, load the STL file.
- 3 Auto Light Automatically adjusts the projector light brightness.
- 4 Scan Start scanning.

■ Scan Edit Tool

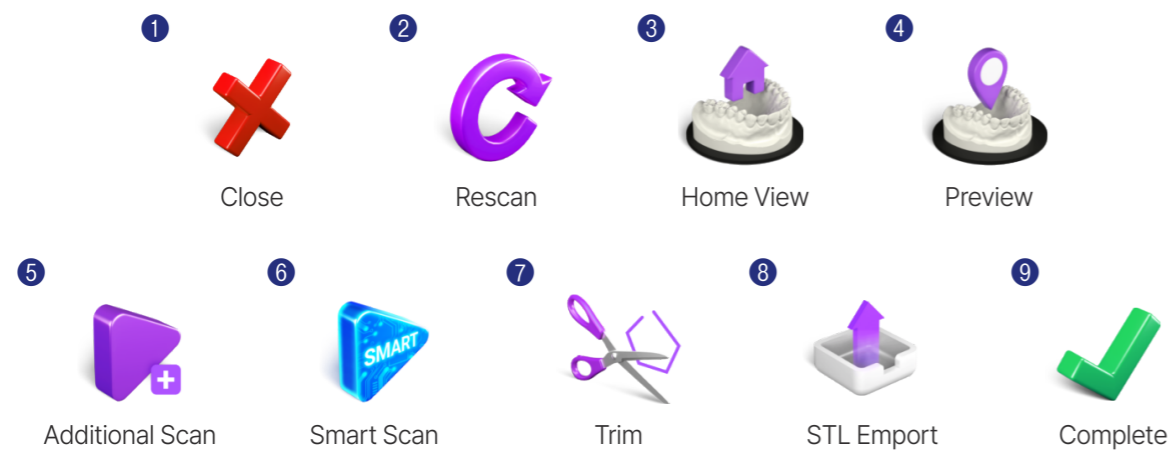

- | | |
|-------------------|---|
| 1 Close | Cancel the scanning step and return to previous task. |
| 2 Rescan | Clear the scanned data and proceed with scanning again. |
| 3 Home View | Move the scanner to the home position. |
| 4 Preview | The scanner's base table and arm move to the angle shown on the screen. |
| 5 Additional Scan | Additional scans are made of areas that were not scanned. |
| 6 Smart Scan | Additional scans of other models can be combined into one data. |
| 7 Trim | Delete unnecessary data. |
| 8 STL Export | Outputs the current scan data as an STL file. |
| 9 Complete | Complete the scanning steps. |

■ Smart Scan Tool



- | | |
|------------------------------|--|
| 1 Close | Cancel the scanning step. |
| 2 Quick Scan | Quickly and simply scan your model and merge it with existing data. |
| 3 Buccal Interproximal | The buccal interproximal area is scanned and merged with existing data. |
| 4 Lingual Interproximal | The lingual interproximal area is scanned and merged with existing data. |
| 5 Impression | Impressions are scanned, inverted and merged with existing data. |
| 6 Stone Model | The stone model is scanned and merged with the impression scan data. |
| 7 Stone Model Separated Data | Scanning the stone model and the impression scan by merging or separate the save data. |
| 8 Impression Scanbody | Simultaneously scan the impression and scan body. Merge with existing impression data. |
| 9 Inner Waxup | Scan the inside of the waxup and merge it with the data on the outside of the waxup. |

Smart Scan Tool

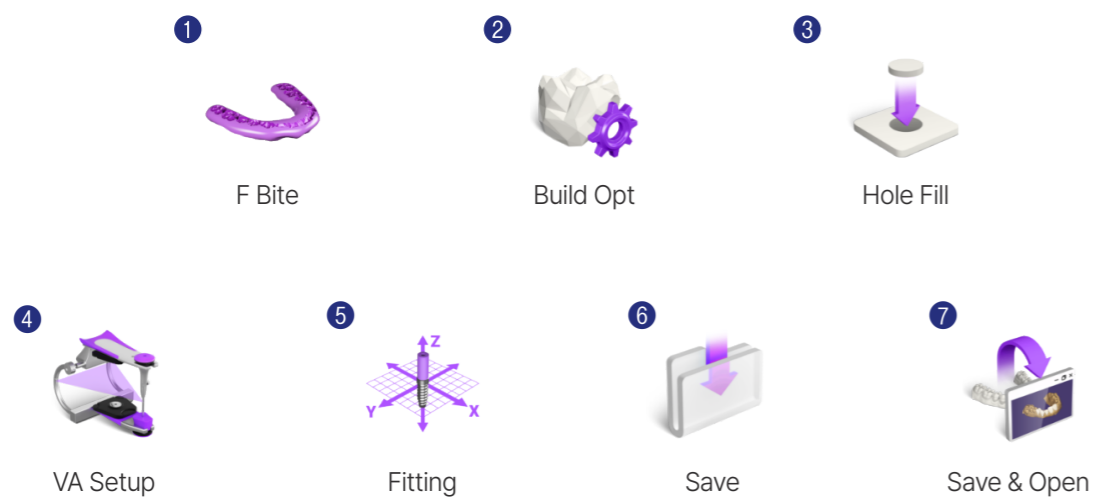

- 1 F Bite Scan the Face Scan Bite.
- 2 Build Option You can modify the build resolution of scan data.
- 3 Hole Fill You can fill in blank spaces in scanned data.
- 4 VA Setup If the adjustable articulator option is selected, scan data align with virtual articulator position.
- 5 Scanbody Fitting Define the position of the scan body and output the value.
- 6 Save Save completed scan data.
- 7 Save & Open After saving the scanned data, run the CAD program.

Scan Parts



- 1 Upper model Upper model scan
- 2 Lower model Lower model scan
- 3 Prep die Prep die scan
- 4 Preop Preop scan
- 5 Wax up Outside of wax up scan
- 6 Scanbody Scanbody scan
- 7 Multi die Multi die scan
- 8 Gingiva Gingiva scan
- 9 Bite scan Bite scan
- 10 Bite rim Bite rim scan
- 11 Articulator Articulator scan
- 12 Upper impression Upper impression scan
- 13 Lower impression Lower impression scan
- 14 All-in-one All-in-one scan
- 15 Face Alignment Bite Face alignment bite scan (Old)
- 16 F Bite Face alignment bite scan (New)

SCANNING INSTRUCTIONS

1 Start SYNC

1 Please enter the business partner, patient name, and staff information and click the next button.

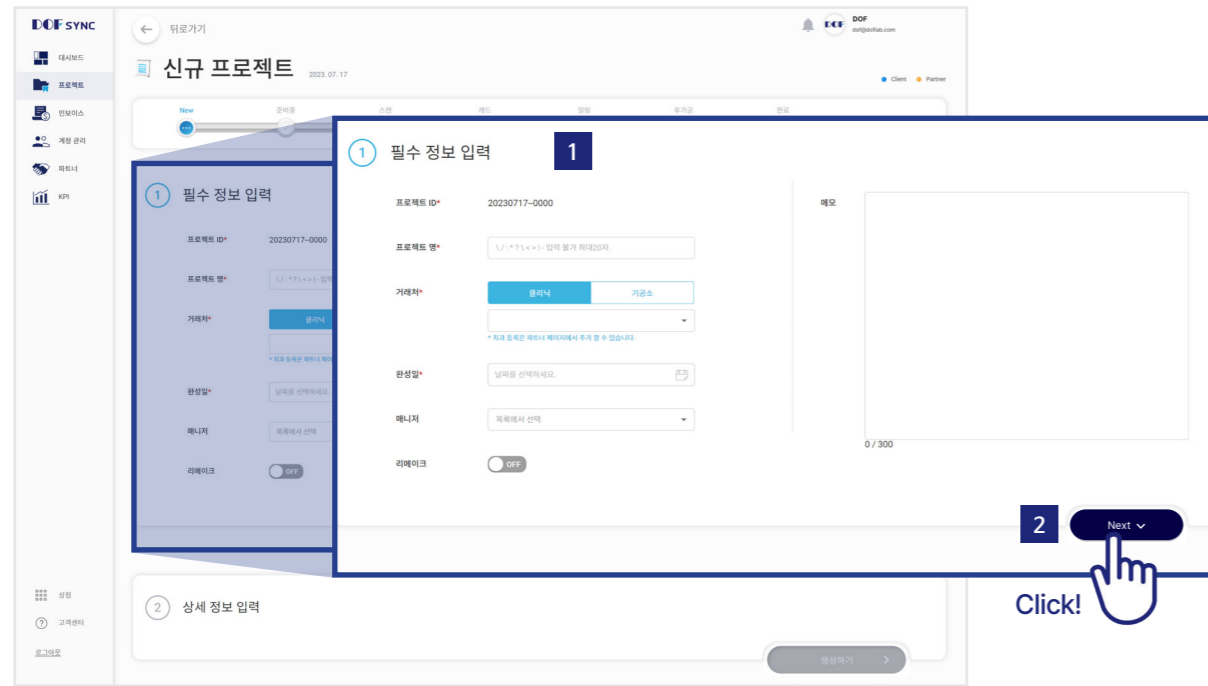

2 Fill in Enter Details, select the crown you want to work on.

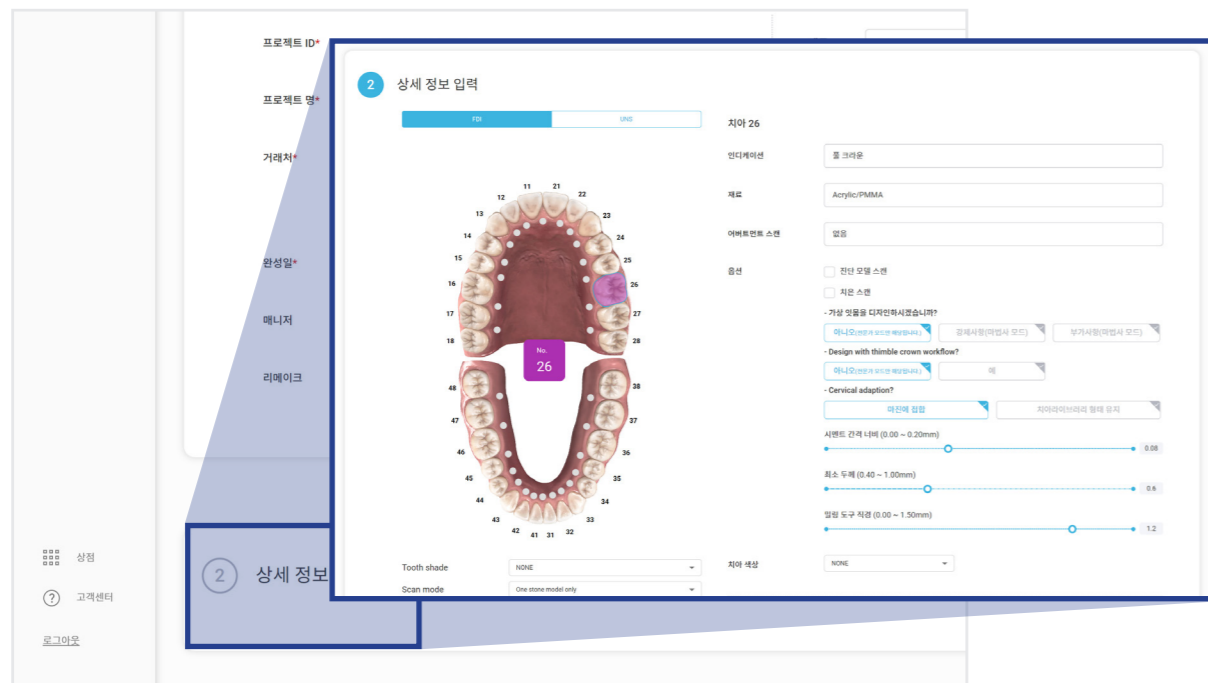

3 After completing the information, click the Create button.

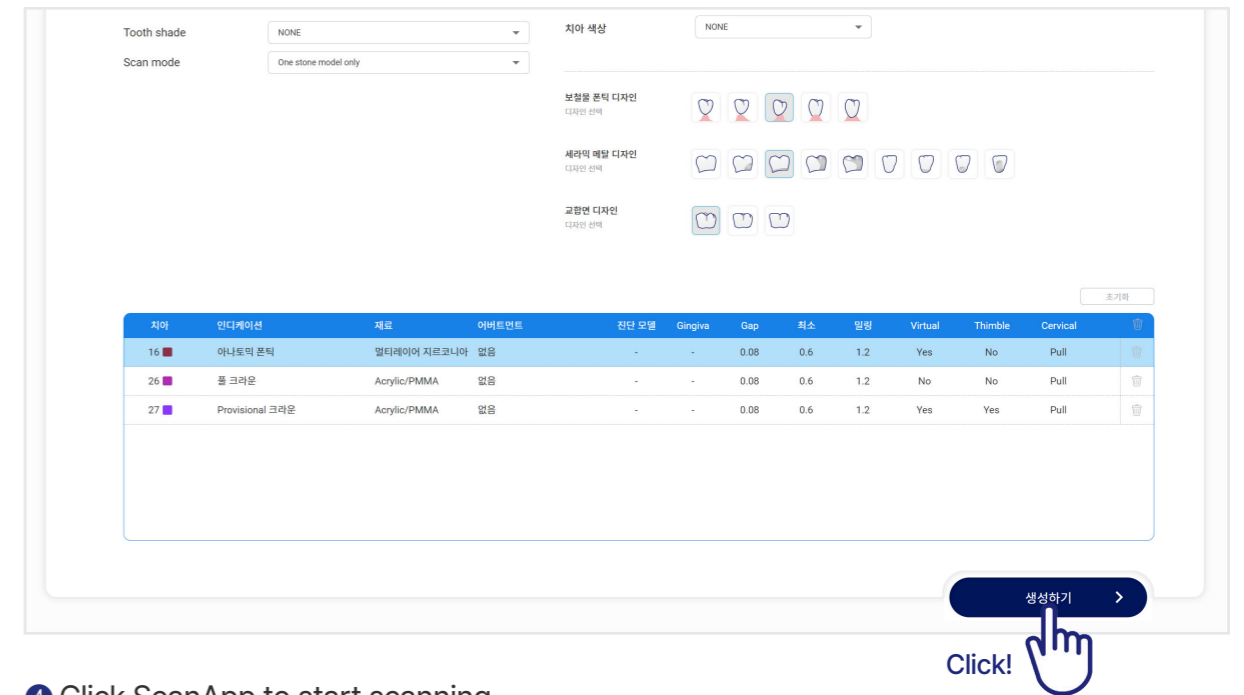

4 Click ScanApp to start scanning.

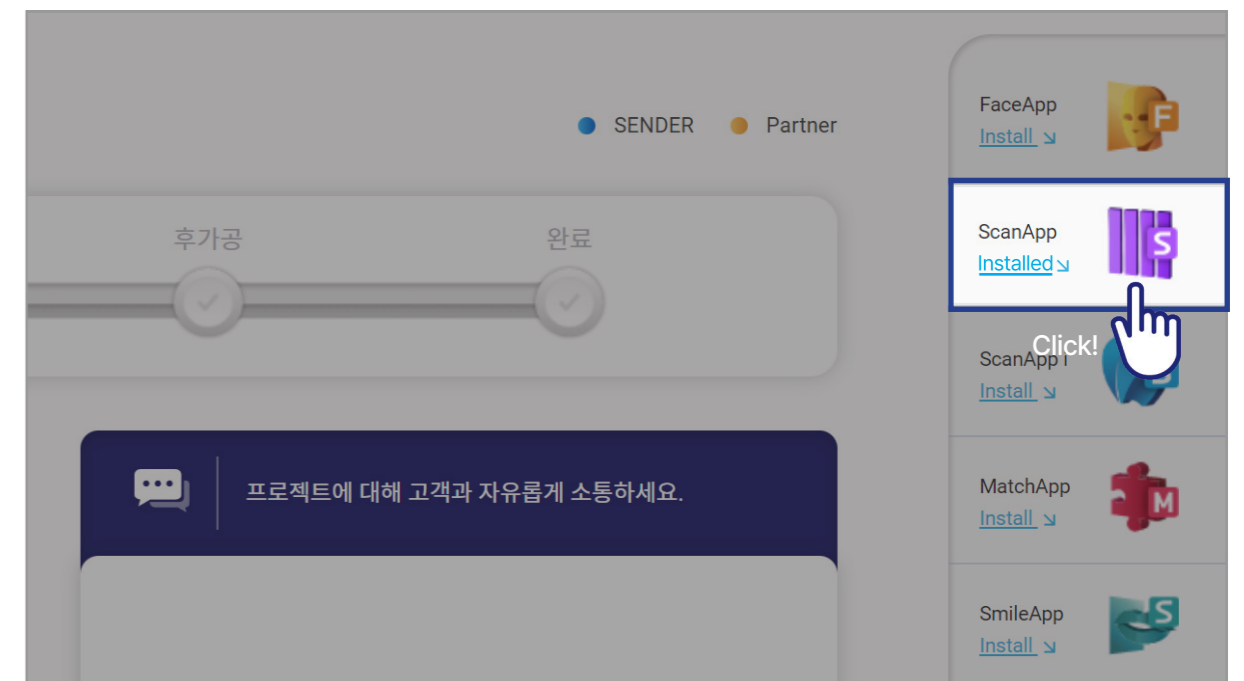

2 Start ScanApp

Scanning strategy guides you through the scanning process.

Customized strategies are provided depending on the prosthesis type and model type.

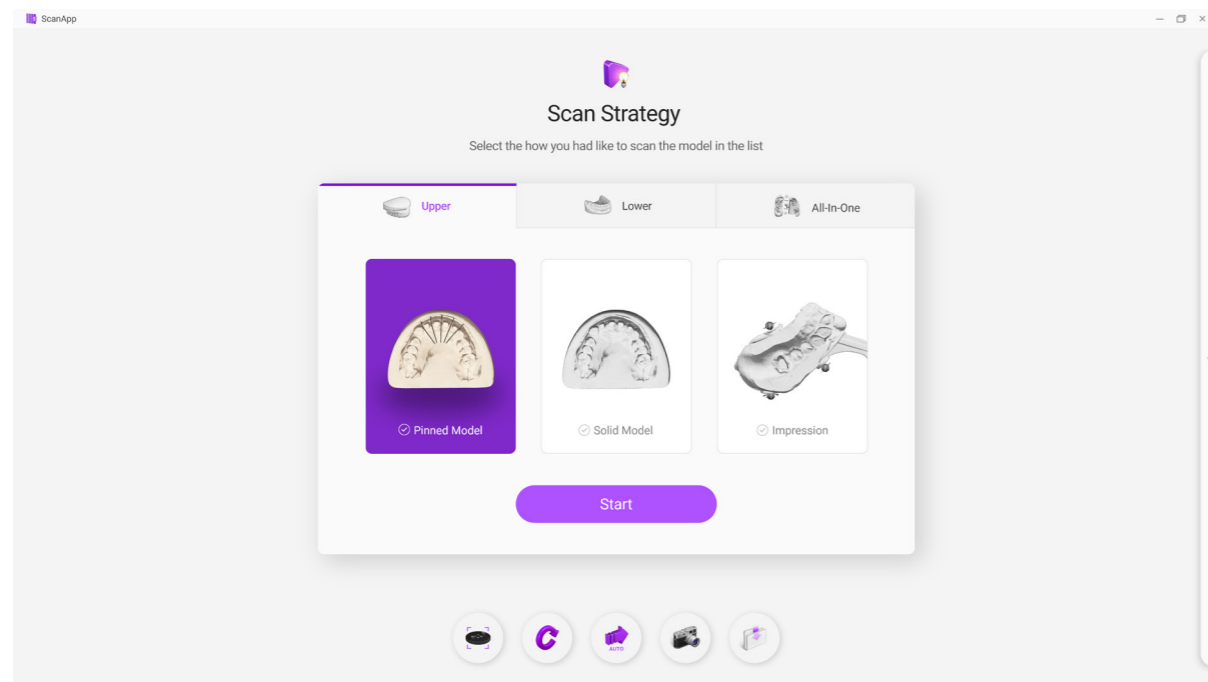

3 Put the model on the scanner

- 1 Use a mesh mat to prevent your model from slipping.
Position the model so that its labial side faces the projector.



- 2 You can check the model's position in live view.
Position the model so that it does not extend out of the live view.

- ③ Adjusts the amount of projector light. The more red dots you see, the brighter the projector light. When scanning, please set the red dot to be very subtle on the abutment area. It is more convenient to use the Auto Light function, but recommended to manually adjust the brightness depending on the model characteristics. When you deselect the Auto Light icon, it changes to manual mode.

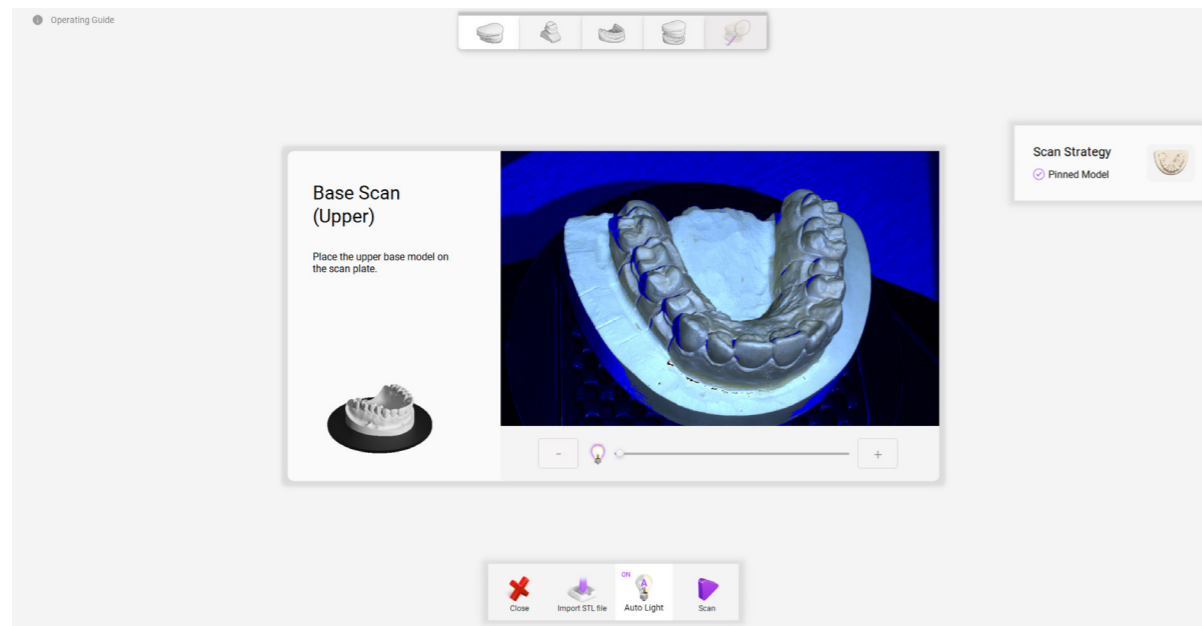
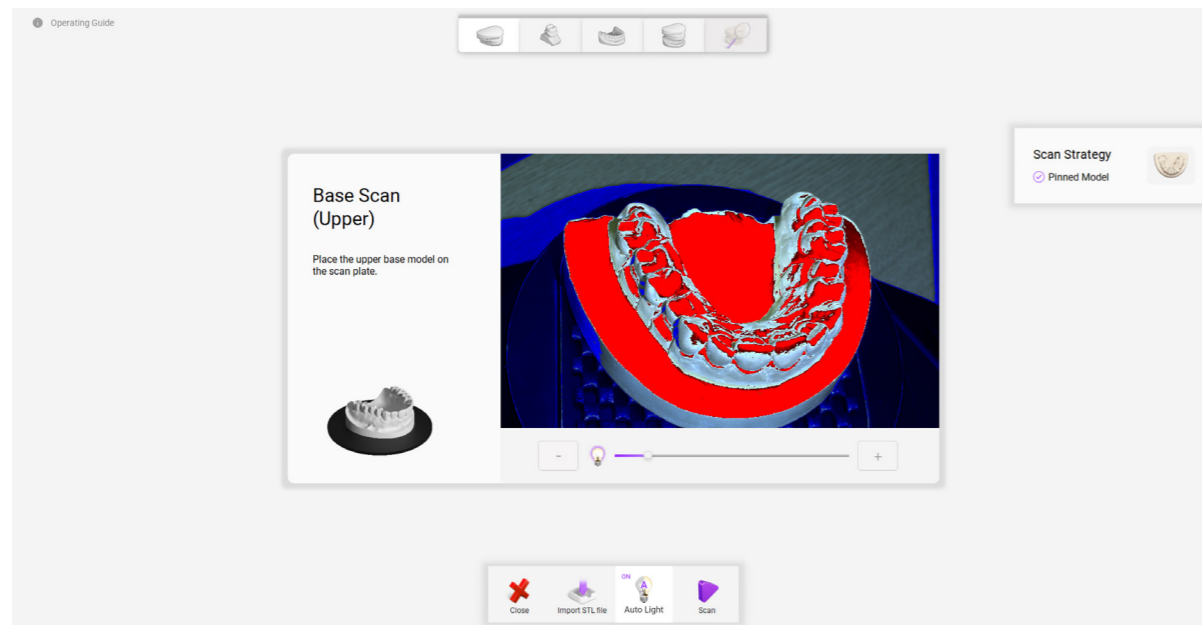

4 Base Model Scan

- ① Position the model correctly on the scanner and proceed with scanning.
- ② Click the scan button to start scanning.

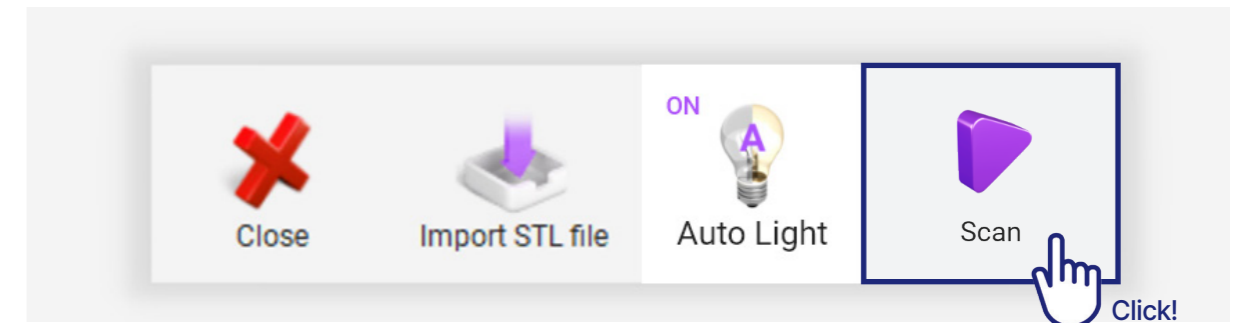

- ③ During Base Scan Stage, the teeth surrounding the abutment teeth are scanned. The abutment scan is performed after the base scan is completed. The base scan is used to distinguish the adjacent teeth from the abutment teeth after scanning the abutment teeth.
- ④ In the Base Scan Stage, check whether the adjacent tooth contact surface has been scanned properly, If insufficient, please perform additional scans.

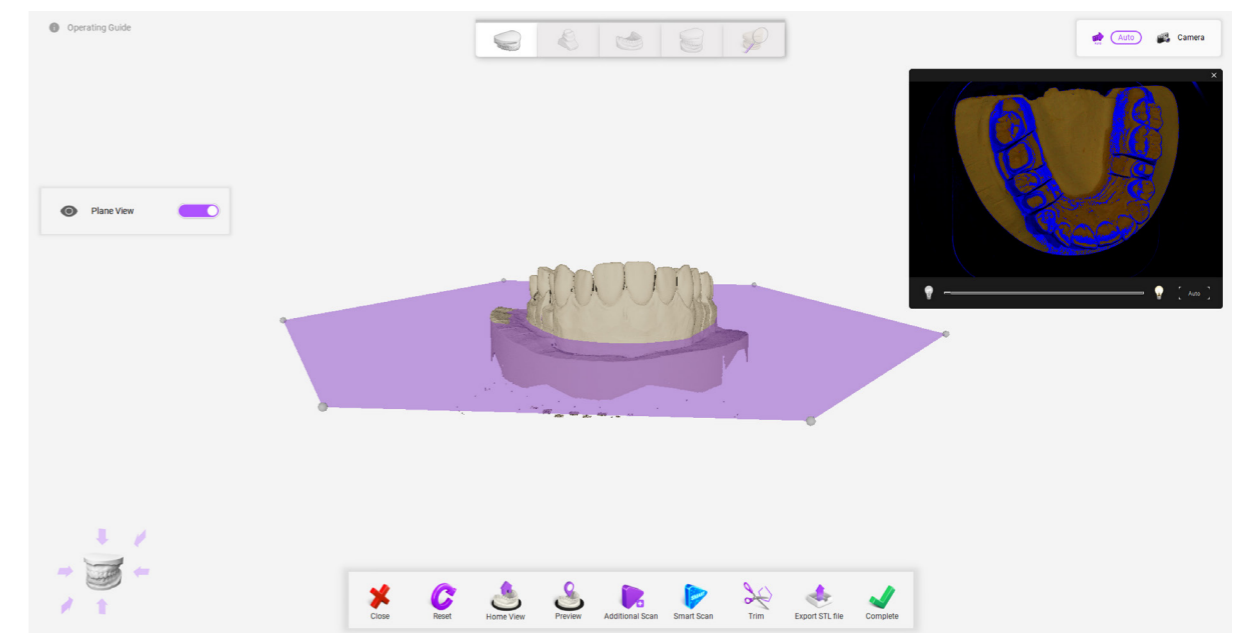

5 Additional Scans and Edit

- 1 After completing the base scan, move the 3D data shown on the screen for additional scan in the unscanned area.
- 2 Additional scanning methods
 - Drag while holding down the left mouse button for additional scan.
 - Click the Additional Scan button in the Edit menu for additional scan.
 - Press the 'S' button on the keyboard for additional scan.

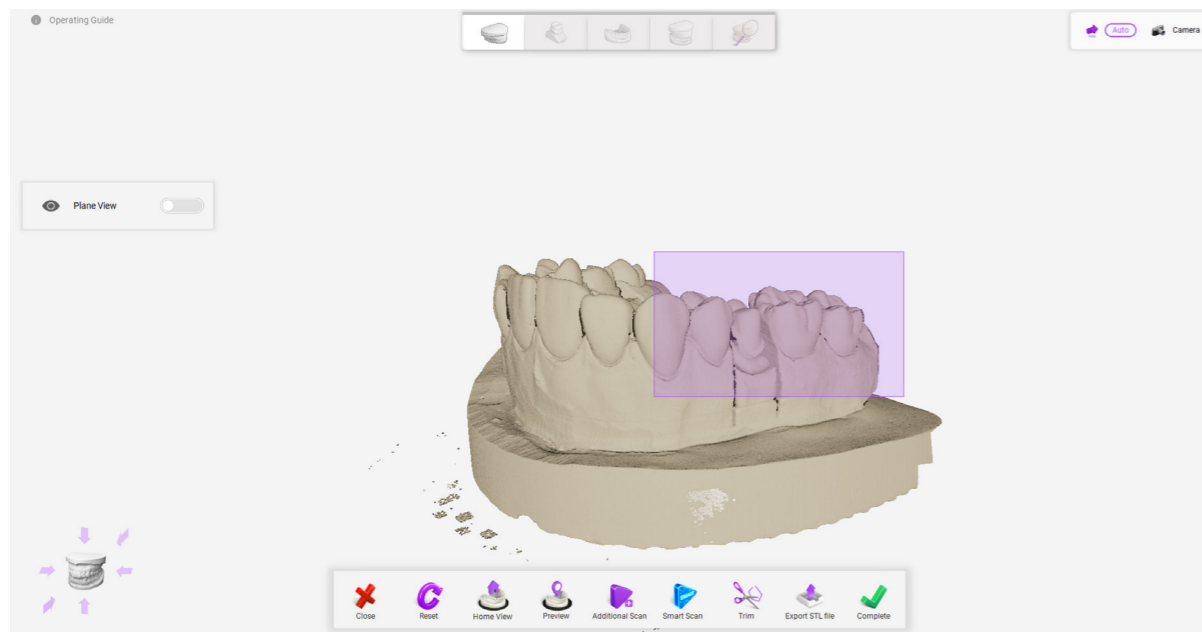

- 3 You can remove unnecessary parts by pressing the Trim button in the Edit menu.

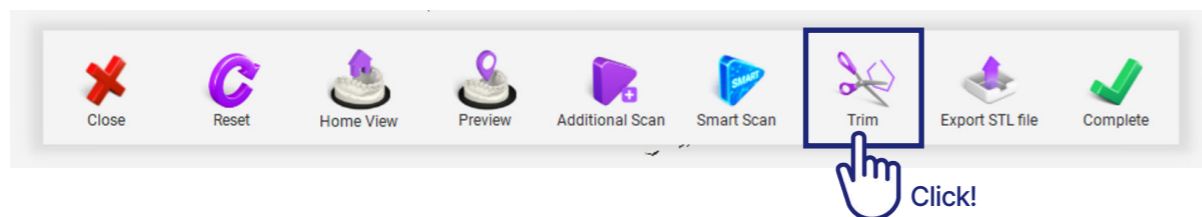

- 4 Once everything is done, click the Complete button to move to the next step.

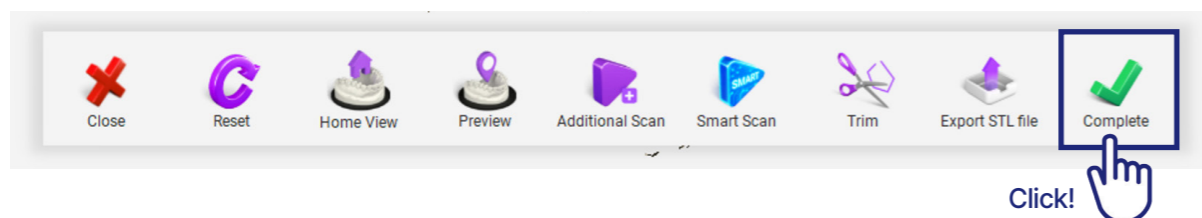

6 Prep Scan

- 1 Once the base scan is completed, proceed to the prep scan step.
Please remove adjacent teeth excluding abutment teeth.
For bridge cases, number information about the abutment to be scanned appears on the left side of the live view. Leave the prep as per the information and remove the remaining models. Select the prep to be scanned in live view.
- 2 On the live view screen, left-click to select the prep to be scanned.
The circular border can be adjusted larger/smaller by scrolling the mouse.
The prep must be placed within the circular border and scanning outside the circular border will not occur.
- 3 Once you have finished specifying the prep scan area, press the scan button to proceed with the scan.
- 4 Once the prep scan is complete, proceed to further scanning and editing steps.
Scan additional parts you need or edit unnecessary parts.
- 5 After completion, press OK button to move to the next step.

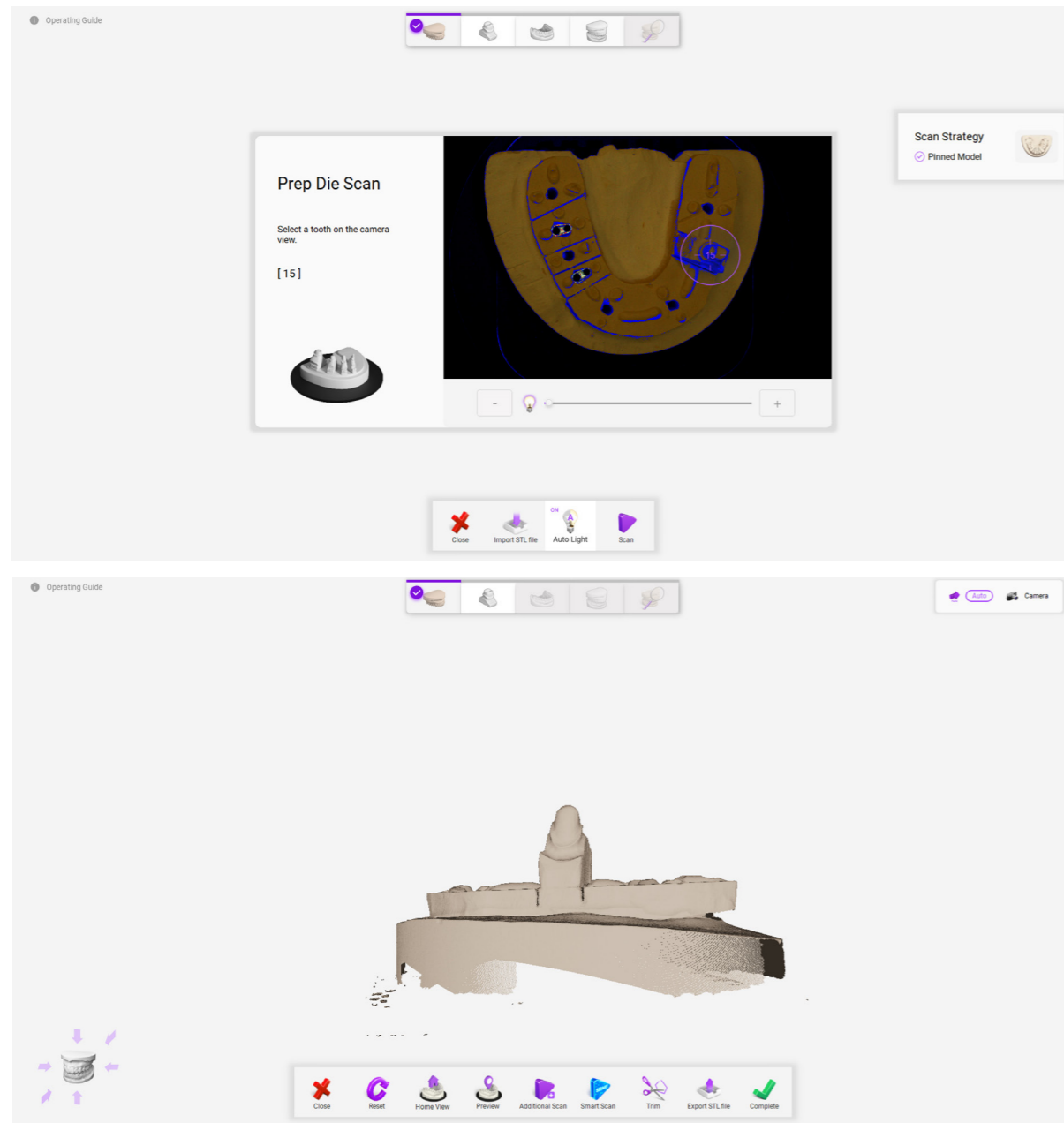

7 Antagonist Scan

- 1 Place the antagonist model on the base plate and click the Scan button to scan.
- 2 After checking the antagonist scan data, add and edit it.
- 3 After completion, press OK button to move to the next step.

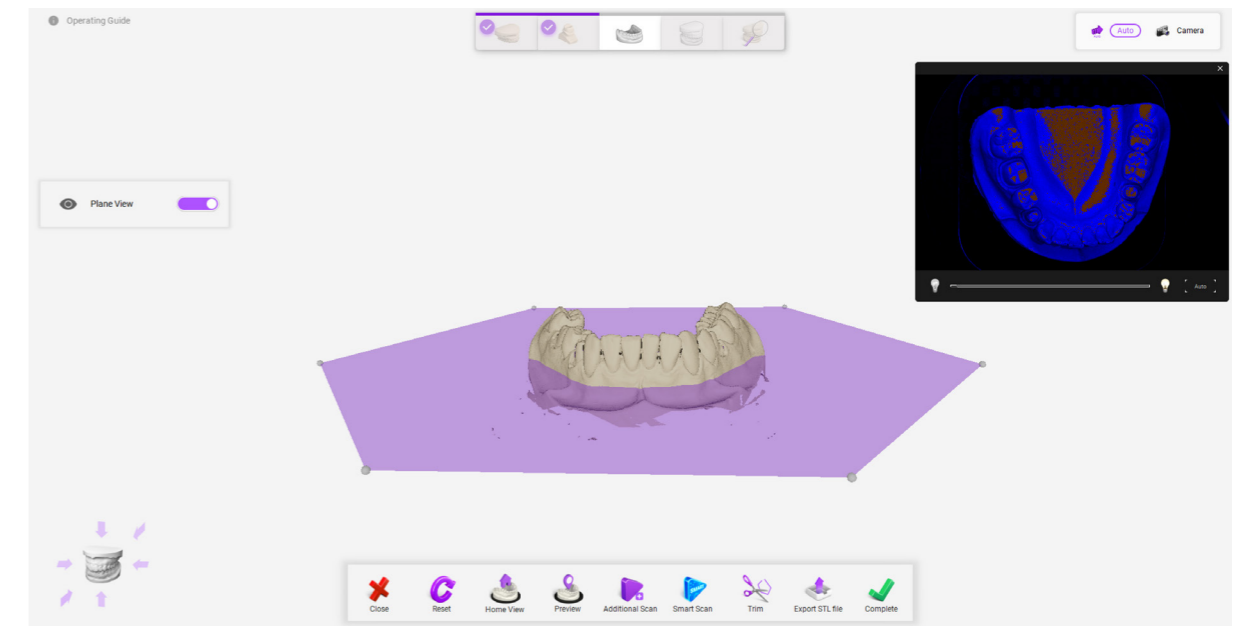

8 Occlusion Scan

- 1 Place the upper and lower jaw model on the scanner and proceed with scanning.
- 2 The 'Upside down placement of articulator' function requires that the lower jaw model be placed upward depending on the situation. In this case, if you check this function and proceed with the scan, the scanned data will be in correct mandible placement. It will change automatically.

- ③ Stone model and non-adjustable articulator scan : After placing the stone model and non-adjustable articulator on the scanner you can proceed with scanning. The camera moves up and down to scan the occlusal relationship.
- ④ Adjustable articulator : After removing all base plates, place the entire adjustable articulator on the scanner. By removing the articulator incisor pin, you can scan for a better occlusal relationship.

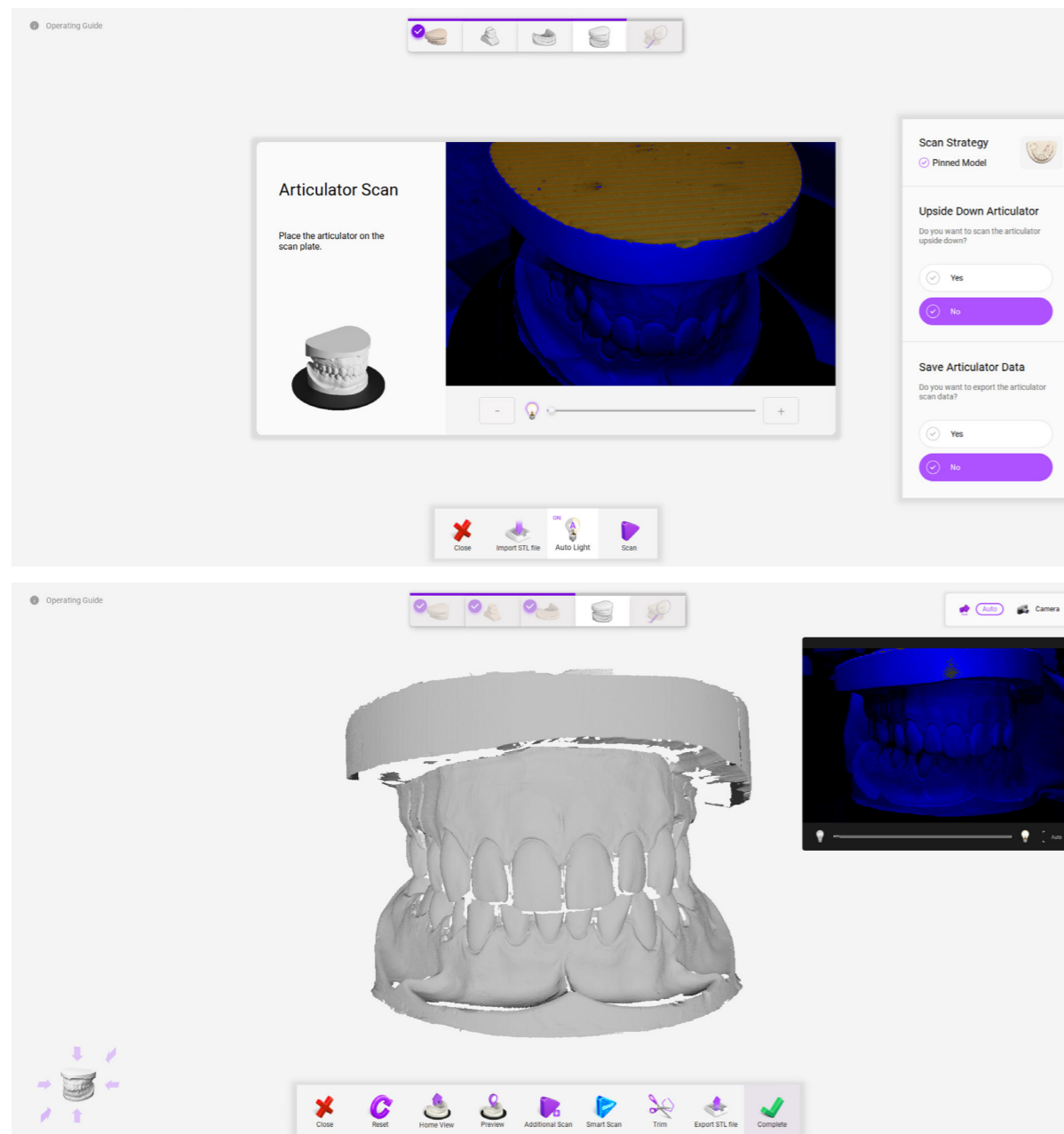

9 Sort scan data

- ① Scan data alignment occurs automatically in the background while scanning is in progress.
- ② You can check the sorted data when the scanning process for one arch is completed.
- ③ For example, in a scanning process that proceeds in the order of base, abutment and wax-up, the sorted data can be checked after the wax-up scan is completed.
- ④ Sorting may fail due to dissimilar data or errors. In this case, you can manually sort the data by clicking the Matching button.
- ⑤ Sort the data by clicking Matching using 3 points in common areas. Sorting is possible with just 1 or 2 points. When sorting data, dots must be set equally in common areas of left and right scan data.

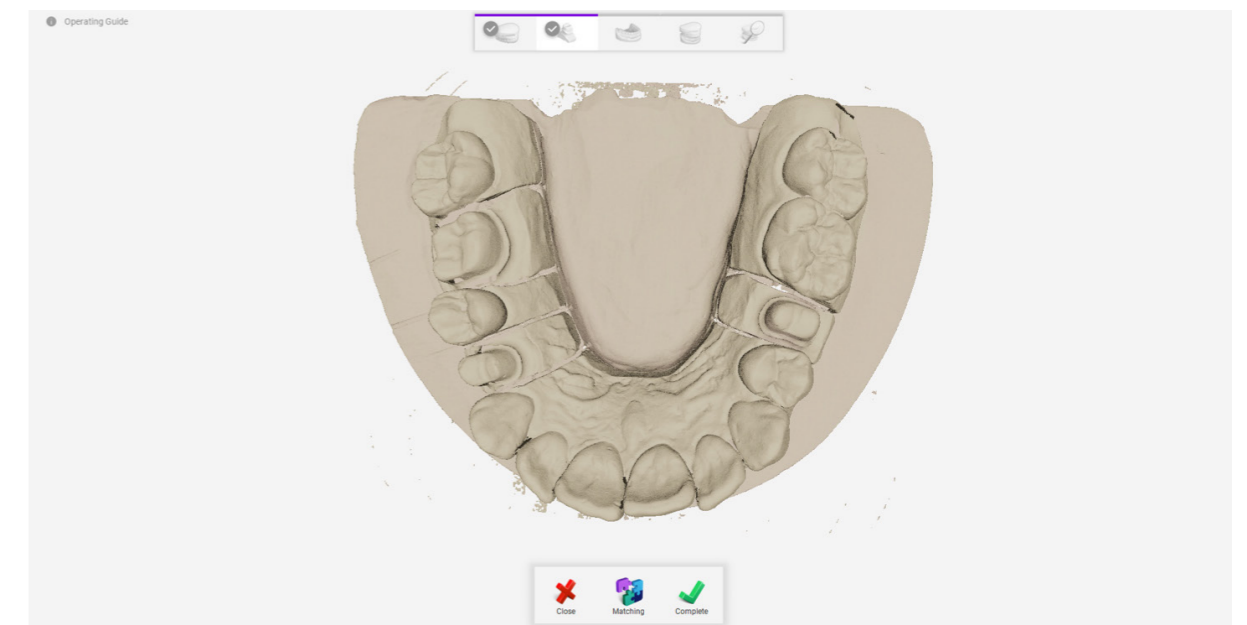

10 Scan Data Build and Edit

- 1 Build converts 3D data made up of points into a mesh structure.
This is the process of creating a file that can be used in CAD.
- 2 The build progresses automatically in the background while scanning is in progress.
- 3 Users can reduce the time it takes to build.
- 4 After all scans are completed, you can check the data for which the build has been completed in the analysis stage.

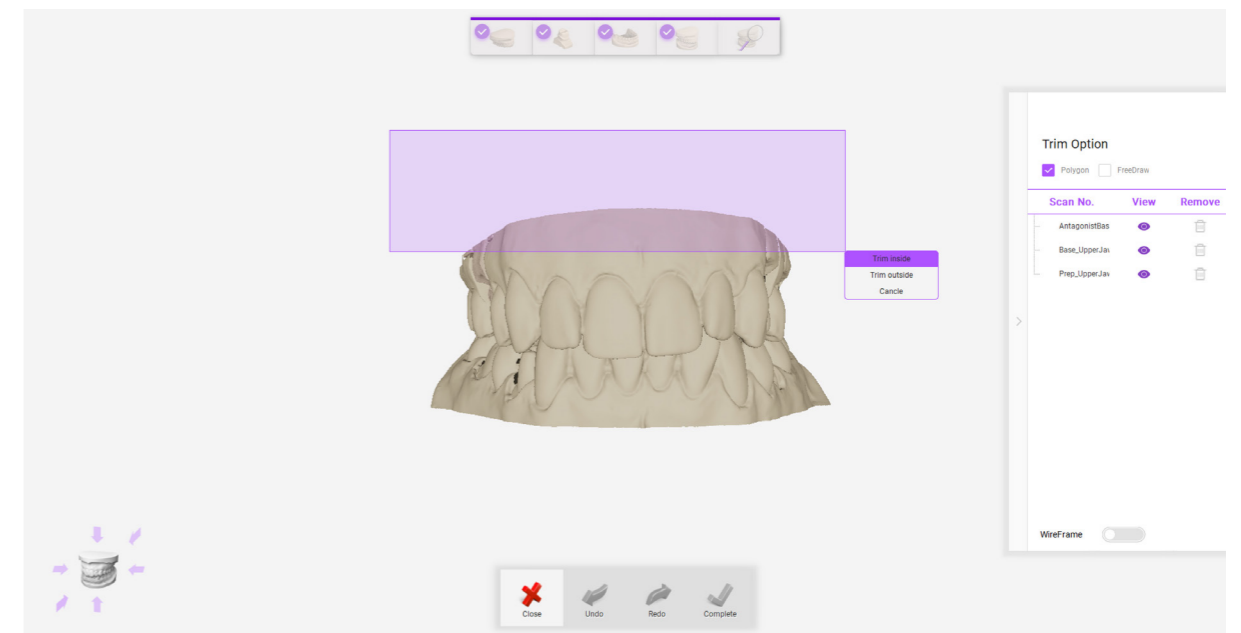
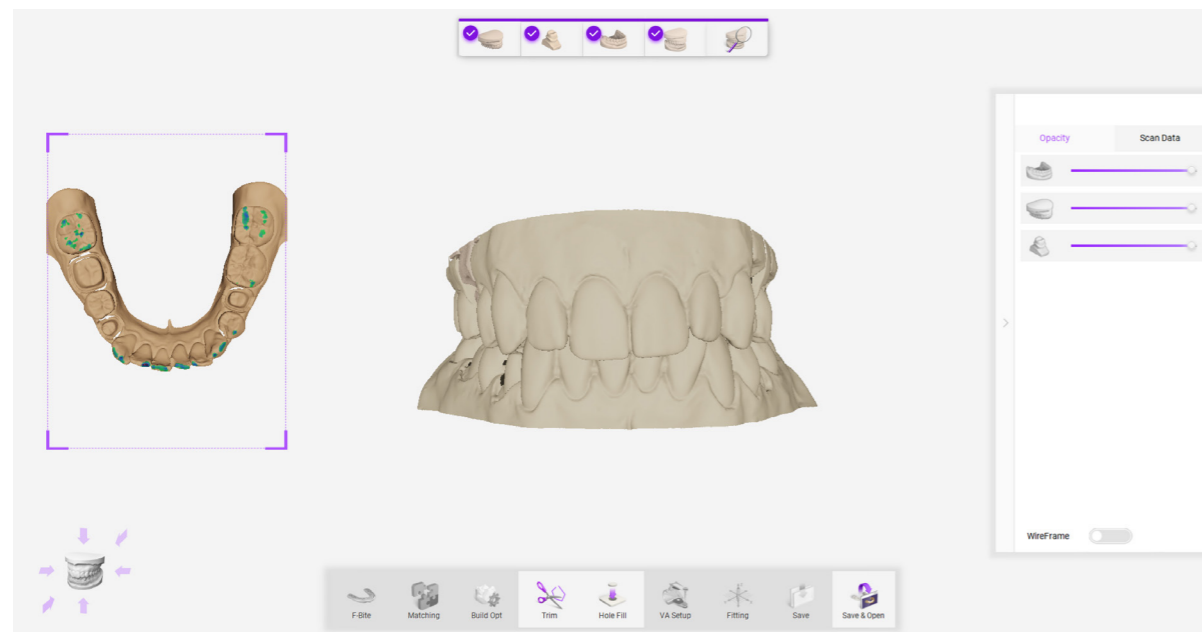

- 5 The file size and resolution of scanned data can be modified in the options before starting scanning.
- 6 After building, you can fill in the empty parts as needed.
However, this function is not recommended for abutment teeth.
Obtain sufficient data during the abutment scanning stage.
- 7 You can edit unnecessary data even after building.
- 8 Click the Save & CAD Open button to start the design.

WORLDWIDE OFFICIAL NETWORK

■ DOF HQ (Korea)

info@doflab.com

+82 70-5057-5861

601-602, 77, Seongsuil-ro, Seongdong-gu, Seoul, 04790 Korea

서울특별시 성동구 성수일로 77 서울숲 IT 밸리 6층 601~602

■ DOF USA

info@doflab.us

+1-949-932-0899

23 Mauchly Suite 107 Irvine, CA 92618

■ DOF Japan

teto@doflab.com

+81 (0)75-741-6542

#301A The Gate Karasuma 78 Manjuji Nakanochō

Shimogyō-ku, Kyoto-shi, Kyoto, 600-8405, Japan

京都市下京区万寿寺通高倉西入万寿寺中之町78 6008405

■ DOF SEA

dofsea@doflab.com

+603 6419 9780

A1-17-11, Arcoris Business Suite Block A1, No. 10,

Jalan Kiara, Mont Kiara 50480 Kuala Lumpur, Malaysia



Copyright © 2023 DOF Inc. All rights reserved.



doflab.com