

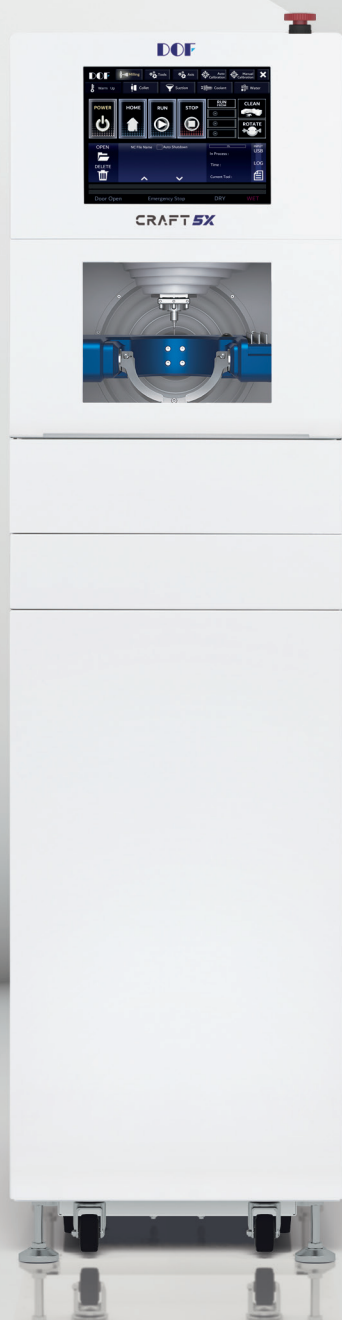

All-in-One Milling Machine

CRAFT 5X





Difference in Detail Derives from Difference in Technology

Everything you imagined, an All-in-One milling machine!
It is more than just a conventional wet and dry milling machine.
A water tank, a dust collector, and a compressor are in one assemblage.
Limitation of materials and limitation of space has been broken down.
CRAFT 5X – compact, superior in strength – where anything is possible.



Wet & Dry

Zirconia, wax, PMMA, hybrid ceramic, glass ceramic and titanium are able to be milled.



5-Axis

Featuring 5-axis simultaneous machining, ideal for cases with severe undercuts and/or multiple insertion angles.



90 Degree Milling

It perfectly reproduces contours of teeth with the 90 degree milling, especially anterior teeth.



One-Step Milling

It mills custom abutments and suprastructures at the same time without the abutment scanning.

CRAFT 5X





The 90 Degree Milling of CRAFT 5X Is Science

CRAFT 5X uses a C-clamp for the 90 degree milling. The externals of teeth can be milled vertically with a block raised to 90 degrees because one side of the C-clamp is open. Delicate milling is possible as it is milling the block at 90 degrees. Tools can get into the undercut areas which cannot be milled at 0 degrees and 180 degrees. In addition, the high-performance motor which precisely controls the milling axes and the rigid frame body made of whole castings enable the error-free 90 degree milling.

0° Milling

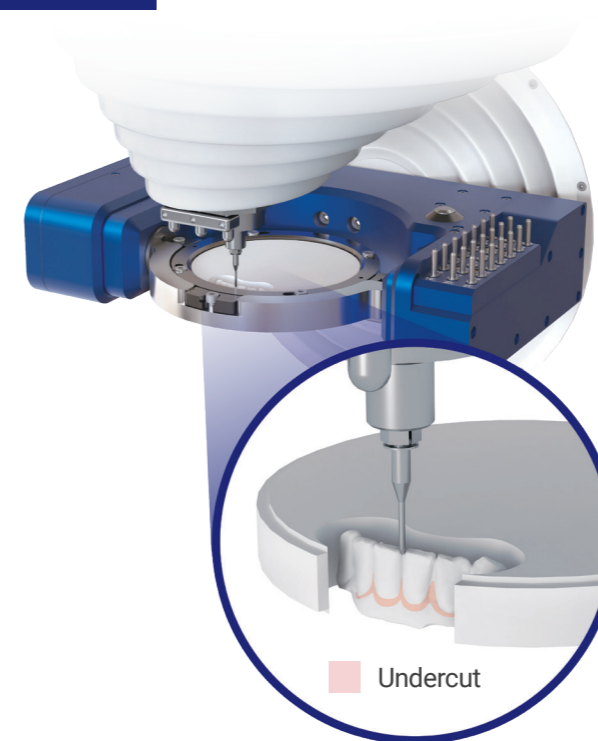

90° Milling



The 90 degree milling is very useful when detailed milling is required like interproximal areas, labial textures, and gingiva lines. Especially, anterior teeth where aesthetic aspects are important. It eliminates the cumbersome process of hand trimming zirconia crowns and dramatically reduces working time.

Live Details Completed with the 90 Degree Milling

CRAFT 5X perfectly reproduces contours of teeth in detail with the 90 degree milling. The 90 degree milling provides great satisfaction with innovative milling methods that goes beyond the conventional framework.



The result of 0° milling



The result of 90° milling



CRAFT 5X Begins the Era of One-Step Milling

Everyone thought one-step milling was impossible, but now experience it with CRAFT 5X. CRAFT 5X extends beyond mechanical limitations of conventional milling machines and reproduces your design as it is. One-step milling is complete by producing the abutments and the suprastructures simultaneously with the 5-axis reverse milling method.

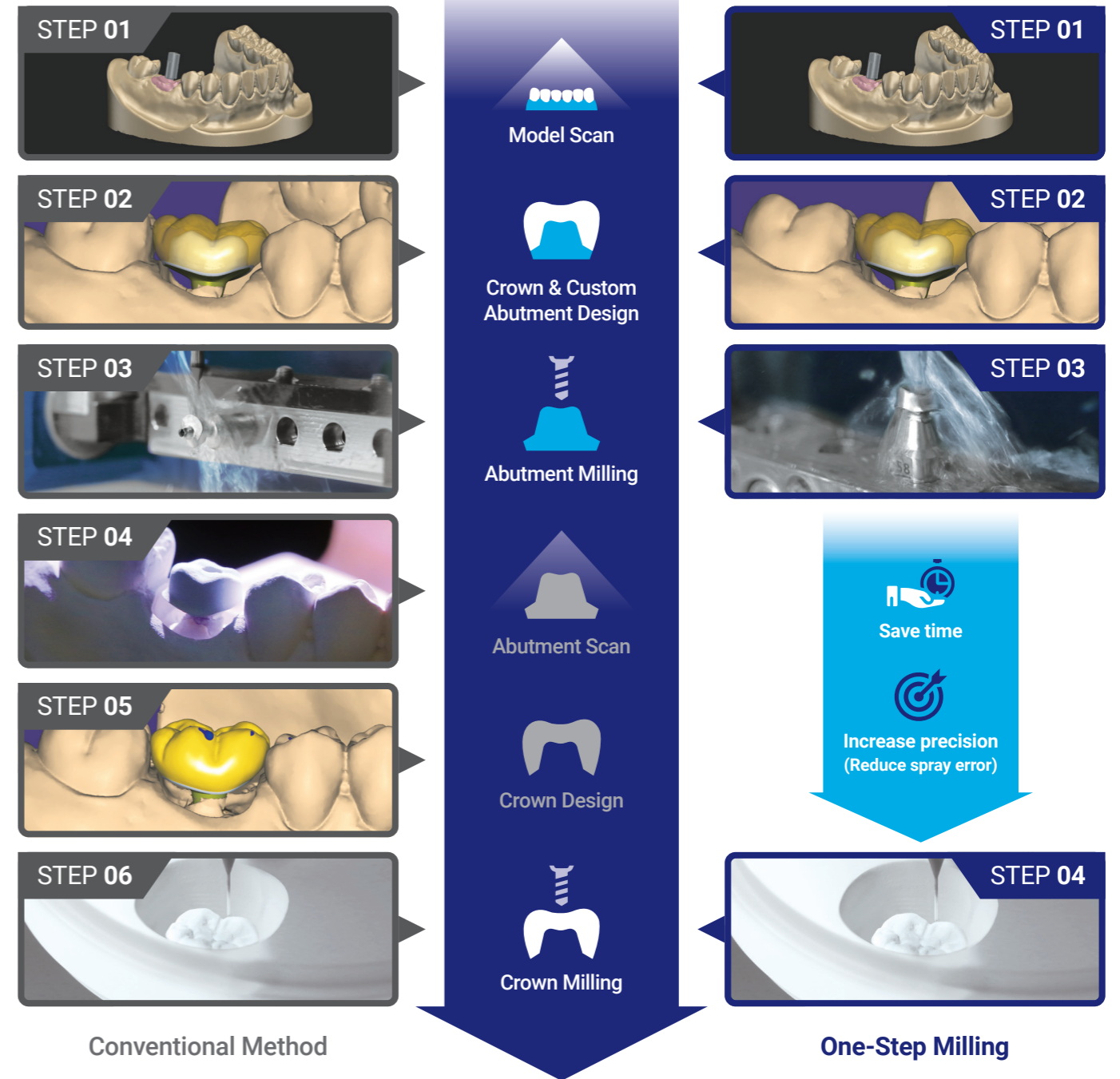

Completely New Abutment Production with One-Step Milling

While conventional custom abutment production goes through complex stages of designing, milling, and scanning the abutment, one-step milling reduces the production stages by milling the abutment and the suprastructure at the same. Save your time more than one day through milling the abutment during sintering the zirconia bridge. It also improves the accuracy by preventing errors that may occur during scanning.

CRAFT 5X

All-in-One

Everything is possible in one machine!
A dust collector, a water pump, and a compressor are all-in-one. CRAFT 5X can be installed anywhere without space restriction. In addition, anyone can use it easily and maintenance is simple.

Dust Collector

Low-noise dust collector motor provides a comfortable & clean environment, and the suction input can be adjusted in four levels.

Coolant System

The coolant system consisting of a water tank and a pump enables milling of glass ceramic and titanium.

Air Compressor

There is no need to install a separate compressor. It is developed with DOF's proprietary technology and achieves space revolution.

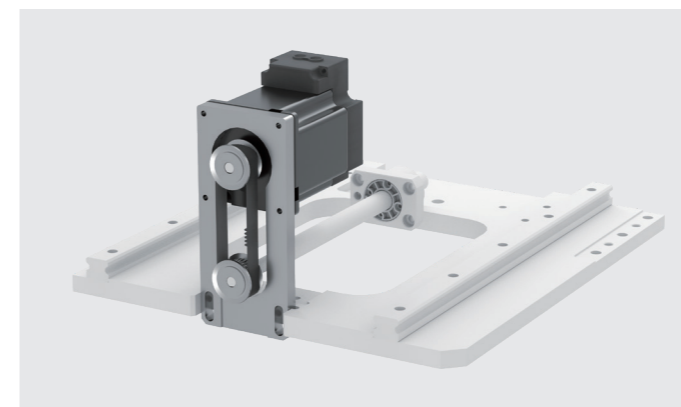
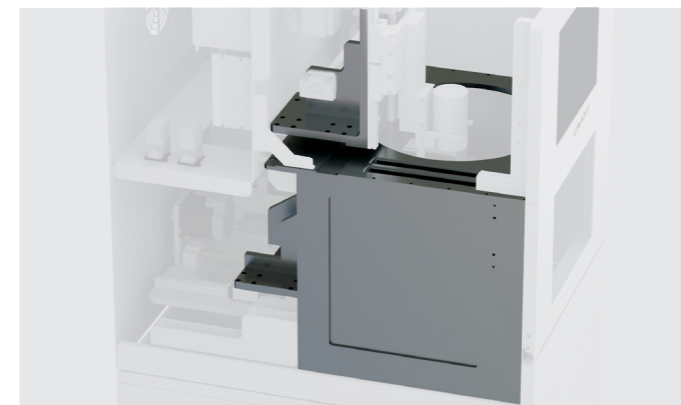
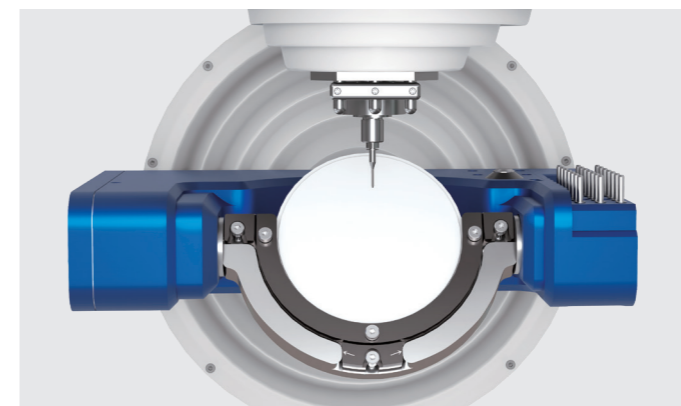

01

Wet & Dry Compatible Milling

Choose between a dry type and a wet type depending on the material. In addition, waterproof sealing protection increases machine longevity.

02

5-Axis Simultaneous Processing

It mills on X, Y, Z axis and rotating blocks and discs 360 degrees in both clockwise and counterclockwise movements. 5-axis milling always allows excellent fits without restrictions on shapes of prostheses.

03

Sturdy & Low-Vibration

Regardless of its compact size, the internal structure of steel components deliver optimal milling speeds with low-vibration for precise milling.

04

Closed Loop

The change in output due to external disturbance are corrected automatically, where the feedback element is always present, resulting in a more reliable and accurate milling mechanism.



05

Onboard Computer

A touch screen and a built-in computer are equipped. The machine control software has an intuitive user interface that anyone can easily use.



06

High Quality Spindle

Durable Jäger spindle, which features up to 100,000 RPM and maximum power of 0.7kw, can mill hard materials stably.



07

Storage

The table provides a storage area where milling accessories can be stored for easy and quick accessibility.

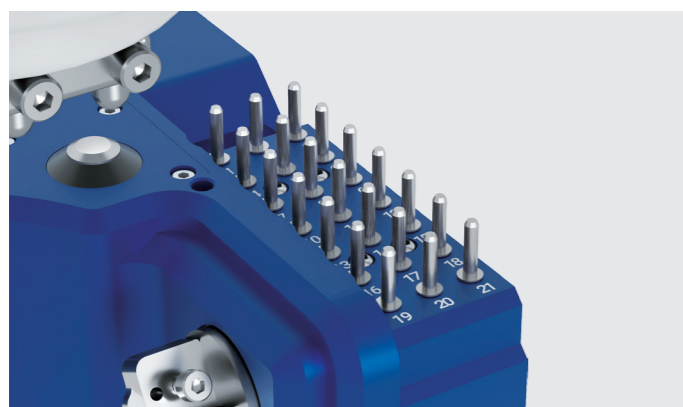

08

21 Station Automatic Tool Changer

Features an automatic tool changer with up to 21 tool seating capacity. Automatic tool sensor measures tool lengths and automatically detects even the smallest discrepancies.

Optional Jig

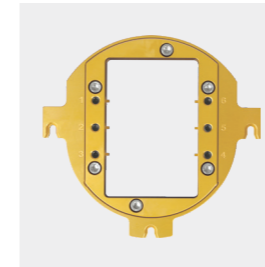

Glass Ceramic Jig

This jig can mill glass ceramic materials.

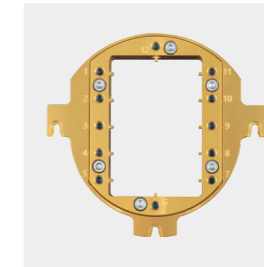

Hybrid Ceramic Jig

This jig can simultaneously mill up to 12 hybrid ceramic materials.

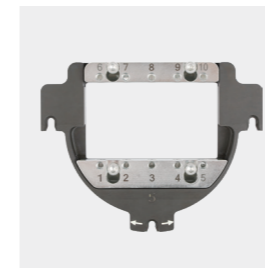

Premill Original Jig

This jig can simultaneously mill up to 10 titanium pre-milled abutments.



Premill Reverse Jig

This jig can mill titanium pre-milled abutments in 5-axis.

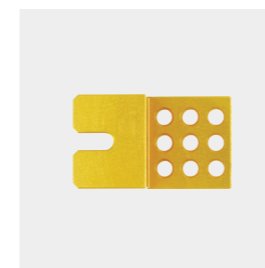

Inlay Holder

Small prostheses such as inlays can be fixed with stones. Inlay milling is possible without connectors.

Specification

Dimensions	Machine	440mm x 660mm x 710mm (W x D x H)
	Table	436mm x 660mm x 1000mm (W x D x H)
Weight	Machine	81kg
	Table	50kg
Spindle	Manufacturer	Jäger
	Shank	4ø
	Maximum RPM	100,000 rpm
	Maximum Power	0.7kw
Number of Tools Housed		21
Number of Pre-milled Simultaneous Milling		10
Number of Reverse Type Pre-milled Simultaneous Milling		6
Number of Glass Ceramic Simultaneous Milling		6
Required Power		1.5kw
Material Compatibility		Zirconia, wax, PMMA, PEEK, composite resin, hybrid ceramic glass ceramic, pre-milled titanium abutment

About DOF Inc.

DOF is a CAD/CAM solution company specializing in developing the world's best 3D dental scanners and dental milling machines. Since the foundation in 2012, DOF has been bringing a new sensation to the industry and has been indicating a rapid growth through developing camera moving scanners. DOF always leads the market through developing innovative products such as Freedom UHD, a 5-megapixel 3D dental scanner boasting the highest precision in the world, and SNAP, a face scanner capable of directly reproducing the face of a patient into 3D data.

DOF promises to grow as we communicate with our customers. Every product provided by DOF is planned and designed through taking into consideration what functions are required by our customers and what may be considered inconvenient by our customers. Even after a product is complete, DOF continuously applies the feedback provided by our customers to improve our products. To help our customers work more conveniently and joyfully is the dream and future DOF envisions.



doflab.com

DOF Inc. #601-602, 77, Seongsuil-ro, Seongdong-gu, Seoul, 04790 Korea (070-5057-3518)

Copyright © 2021 DOF Inc. All rights reserved.

Design and specifications are subject to change without notice to improve performance.

